



HY17P68 DMM Configurations

Table of Contents

1. MILLIVOLTS(MV)	6
1.1. mV Input Network Configuration	7
1.2. DC mV Measurement Network Configuration.....	8
1.2.1. ADC Settings(DC 60mV).....	8
1.2.2. ADC Settings(DC 600mV).....	9
1.3. AC mV Measurement Network Configuration.....	10
1.3.1. ADC Settings(AC 60mV).....	10
1.3.2. ADC Settings(AC 600mV).....	11
1.4. mV Function Power Supply Configuration	12
2. CURRENT	13
2.1. Current Input Network Configuration	14
2.2. DC Current Measurement Network Configuration	15
2.2.1. ADC Settings(DC Lower Range).....	15
2.2.2. ADC Settings(DC Higher Range).....	16
2.3. AC Current Measurement Network Configuration	17
2.3.1. ADC Settings(AC Lower Range).....	17
2.3.2. ADC Settings(AC Higher Range).....	18
2.4. Current Function Power Supply Configuration	19
3. VOLTAGE	20
3.1. 6V Input Network Configuration	21
3.2. 60V Input Network Configuration	22
3.3. 600V Input Network Configuration	23
3.4. 1000V Input Network Configuration	24
3.5. DCV Measurement Network Configuration.....	25
3.5.1. ADC Settings.....	25
3.6. ACV Measurement Network Configuration	26
3.7. ADC Settings.....	26
3.8. Voltage Function Power Supply Configuration	27
4. RESISTOR	28
4.1. 600Ω Input Network Configuration.....	29
4.2. 6kΩ Input Network Configuration	30
4.3. 60k Ω Input Network Configuration.....	31

4.4.	600Ω~60kΩ Measurement Network Configuration.....	32
4.5.	600kΩ Input Network Configuration.....	33
4.6.	6MΩ Input Network Configuration.....	34
4.7.	60MΩ Input Network Configuration.....	35
4.8.	600kΩ~60MΩ Measurement Network Configuration.....	36
4.9.	Resistor Function Power Supply Configuration	37
5.	CONTINUITY.....	38
5.1.	Continuity Input Network Configuration	38
5.2.	Continuity Measurement Network Configuration	39
5.3.	Continuity Function Power Supply Configuration	40
6.	DIODE	41
6.1.	Diode Input Network Configuration.....	42
6.1.1.	Positive Constant Voltage Source Network Configuration.....	42
6.1.2.	Positive Constant Current Source Network Configuration.....	43
6.2.	Diode Measurement Network Configuration.....	44
6.2.1.	Positive Constant Voltage Source Measurement.....	44
6.2.2.	Positive Constant Current Source Measurement.....	45
6.3.	Diode Function Power Supply Configuration	46
7.	CAPACITANCE.....	47
7.1.	60-600nF(Constant Voltage Charge/Discharge Measurement) Network Configuration.....	48
7.2.	6μF-60μF(Constant Current Charge/Discharge Measurement) Network Configuration	49
7.3.	600uF~60mF Capacitor Charging Input Network Setting.....	50
7.3.1.	600uF(Charge) Input Network Configuration.....	51
7.3.2.	6mF-60mF(Charge) Input Network Configuration.....	52
7.4.	600μF~60mF Measurement Network Configuration.....	53
7.5.	Discharge(600μF~60mF) Input Network Configuration	54
7.6.	Capacitance Function Power Supply Configuration	55
8.	FREQUENCY	56
8.1.	Example Of Frequency Counter Calculation	57
8.2.	Analog Input.....	58
8.2.1.	Voltage Input	58
8.2.2.	MilliVolt / Current Input	59

8.3.	Digital Input	60
8.3.1.	CNT Input	60
8.4.	Frequency Function Power Supply Configuration	61
9.	APPLICATION Q&A	62
9.1.	Why is there an error in the voltage function ADC negative terminal selection PBx?	62
9.2.	Continuity and 60MΩ response speed is too slow	63
10.	REVISION HISTORY	64

Attention:

- 1、HYCON Technology Corp. reserves the right to change the content of this datasheet without further notice. For most up-to-date information, please constantly visit our website: <http://www.hycontek.com> .
- 2、HYCON Technology Corp. is not responsible for problems caused by figures or application circuits narrated herein whose related industrial properties belong to third parties.
- 3、Specifications of any HYCON Technology Corp. products detailed or contained herein stipulate the performance, characteristics, and functions of the specified products in the independent state. We does not guarantee of the performance, characteristics, and functions of the specified products as placed in the customer's products or equipment. Constant and sufficient verification and evaluation is highly advised.
- 4、Please note the operating conditions of input voltage, output voltage and load current and ensure the IC internal power consumption does not exceed that of package tolerance. HYCON Technology Corp. assumes no responsibility for equipment failures that resulted from using products at values that exceed, even momentarily, rated values listed in products specifications of HYCON products specified herein.
- 5、Notwithstanding this product has built-in ESD protection circuit, please do not exert excessive static electricity to protection circuit.
- 6、Products specified or contained herein cannot be employed in applications which require extremely high levels of reliability, such as device or equipment affecting the human body, health/medical equipments, security systems, or any apparatus installed in aircrafts and other vehicles.
- 7、Despite the fact that HYCON Technology Corp. endeavors to enhance product quality as well as reliability in every possible way, failure or malfunction of semiconductor products may happen. Hence, users are strongly recommended to comply with safety design including redundancy and fire-precaution equipments to prevent any accidents and fires that may follow.
- 8、Use of the information described herein for other purposes and/or reproduction or copying without the permission of HYCON Technology Corp. is strictly prohibited.

1. Millivolts(mV)

Due to high ADC input impedance, it is easy to sense 50/60Hz signal of the air that leads to unstable reading value after the testing probe was connected. It is recommended to connect input $10M\Omega$ to ground to reduce input impedance of DMM mV range.

The network configuration of 60mV and 600mV is similar. When measuring 60mV, it uses built-in OPA to amplify signal for 8 times then processing it in ADC.

The difference between DC and AC measurement is recommended to enable ADC Chopper function during DC measurement to reduce DC Offset and enable ADC Pre-Filter. On the contrary, it is not necessary to turn on Chopper in AC measurement.

1.1. mV Input Network Configuration

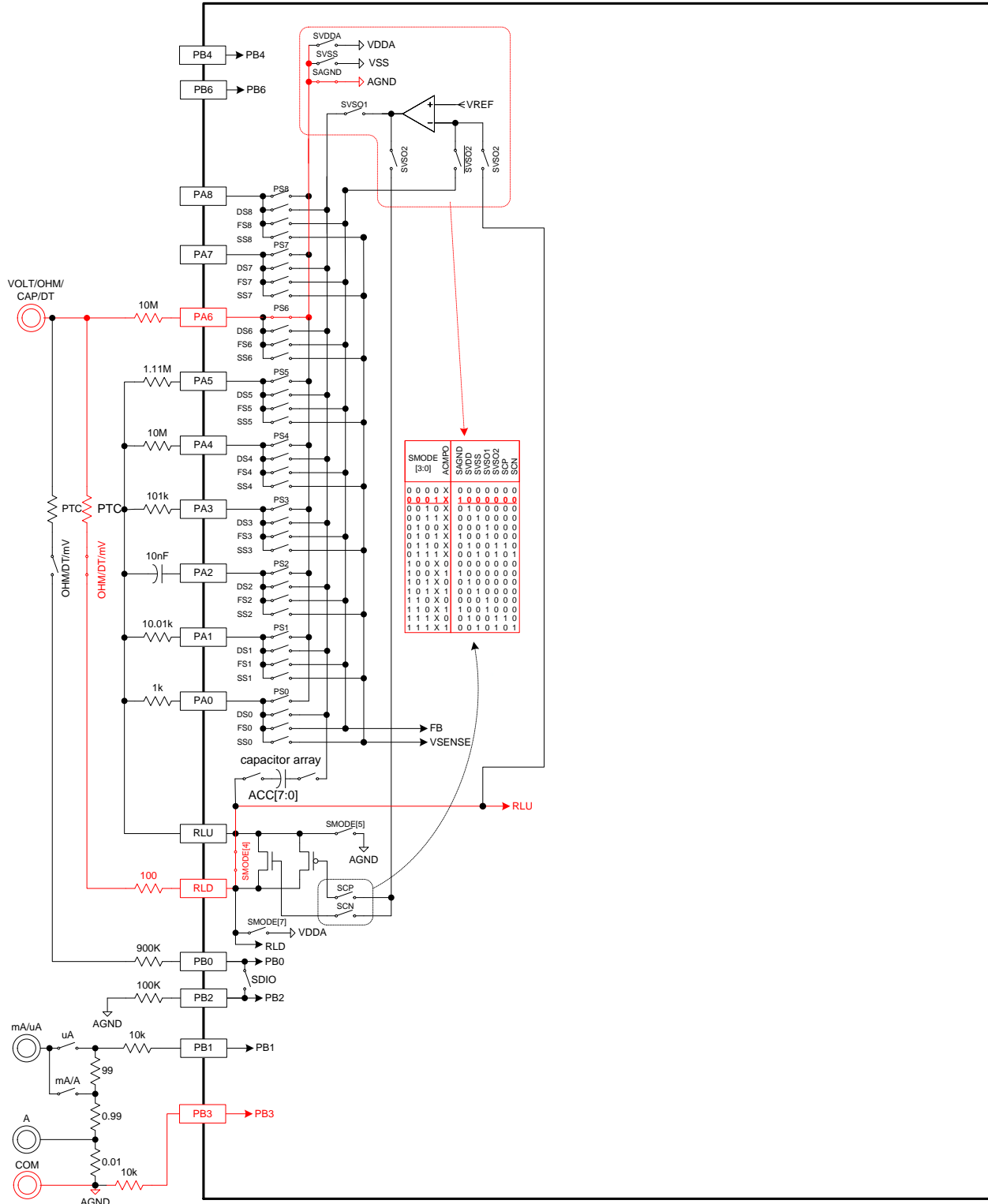

1.2. DC mV Measurement Network Configuration
1.2.1. ADC Settings(DC 60mV)

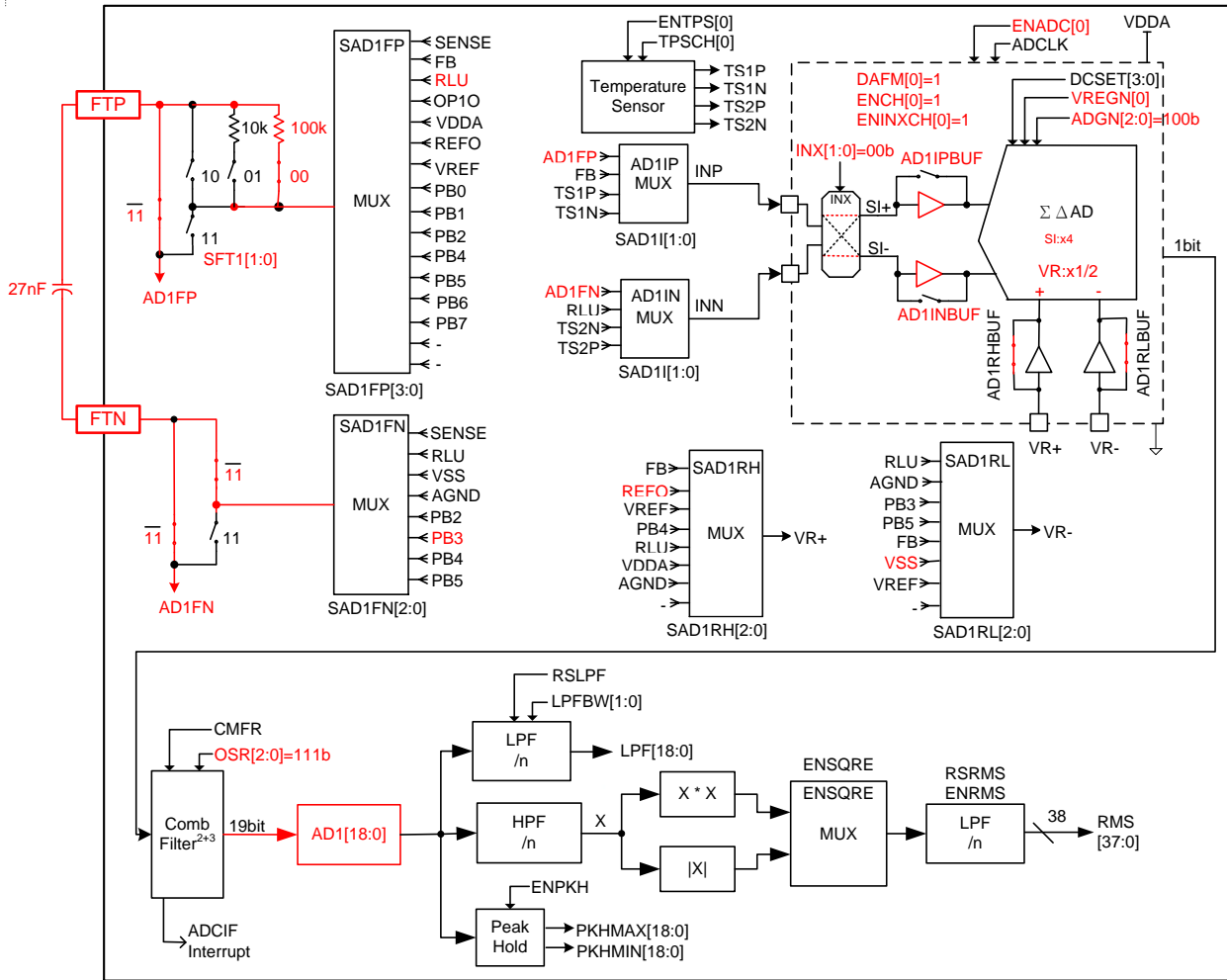

1.2.2. ADC Settings(DC 600mV)

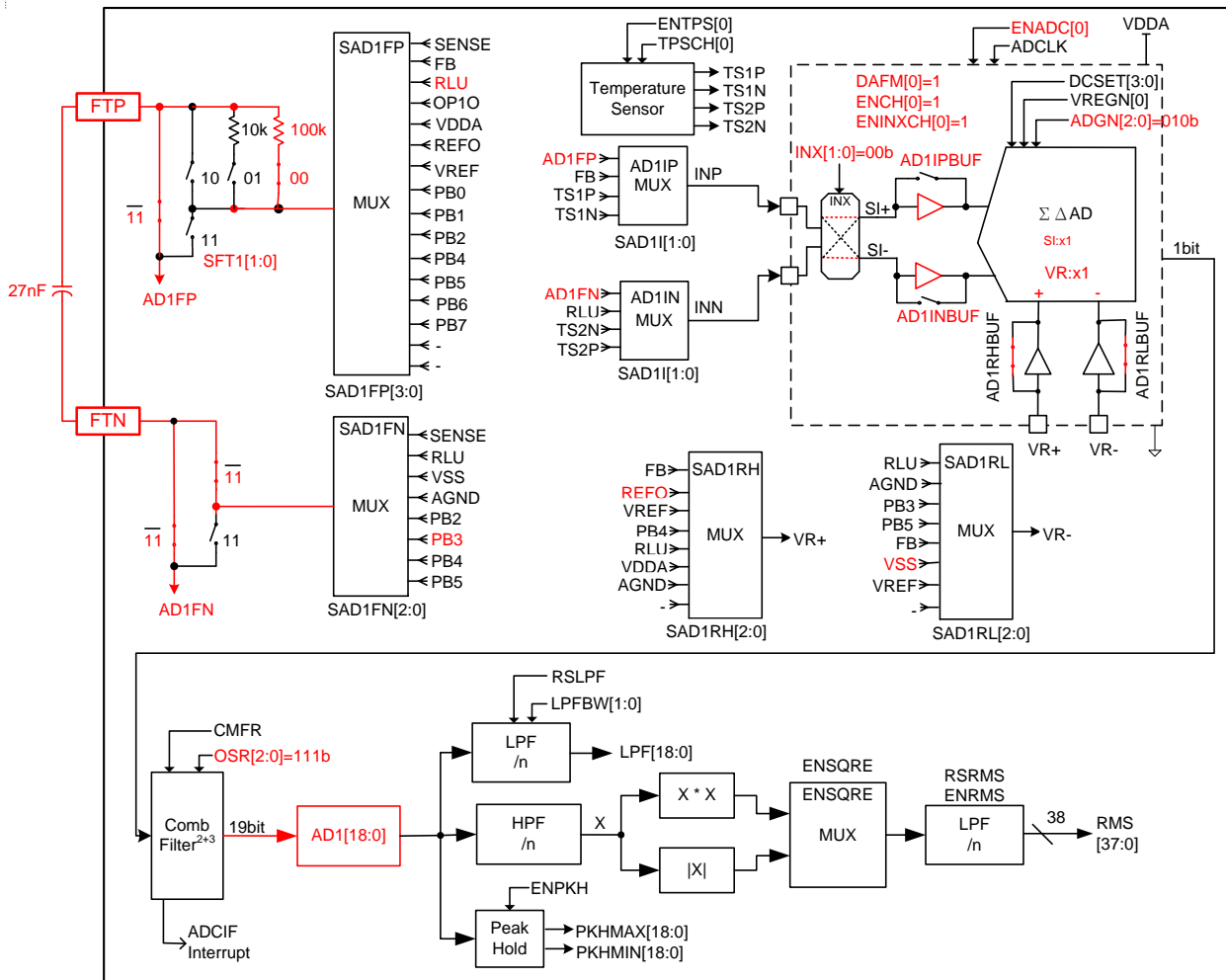

1.3. AC mV Measurement Network Configuration
1.3.1. ADC Settings(AC 60mV)

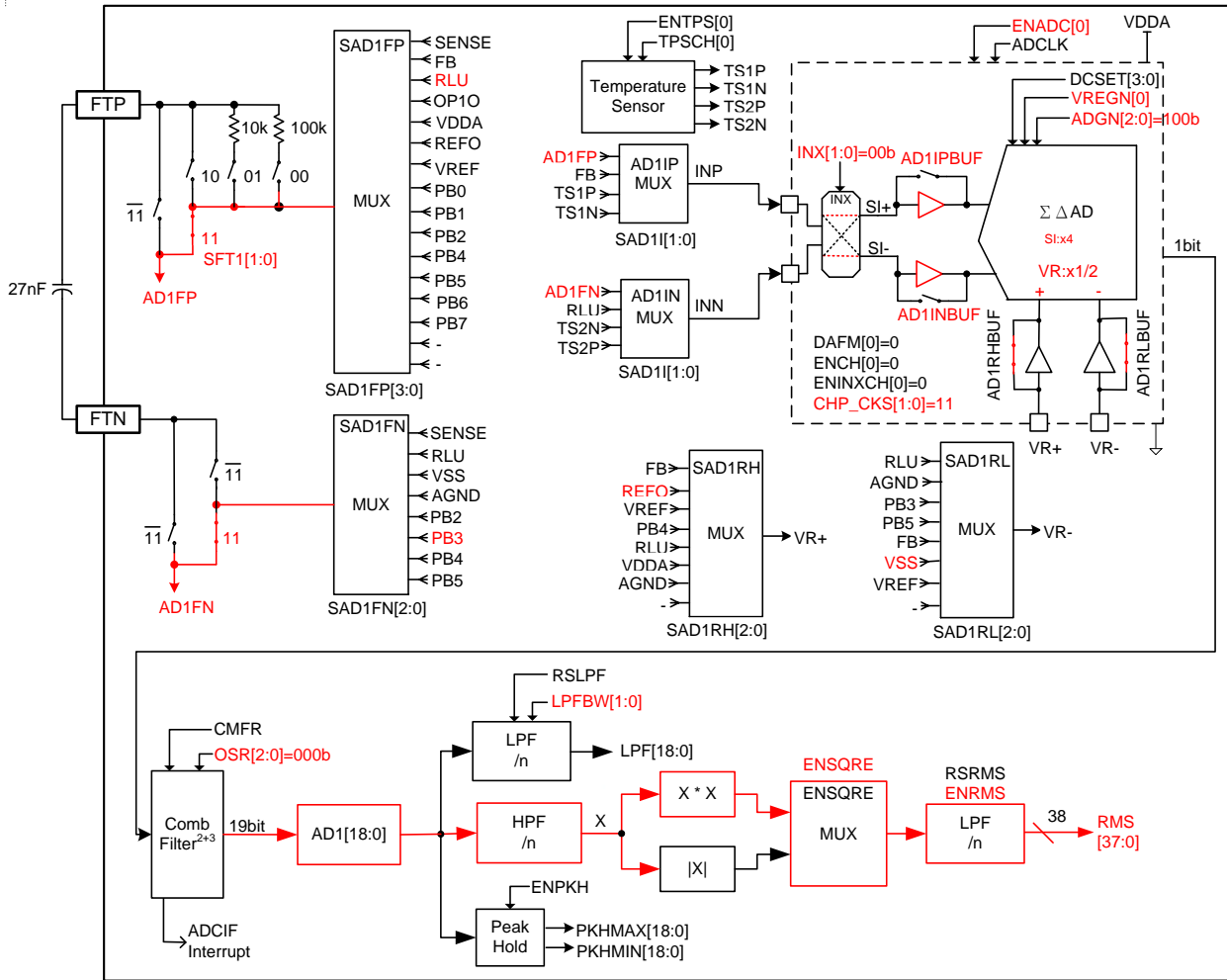

1.3.2. ADC Settings(AC 600mV)

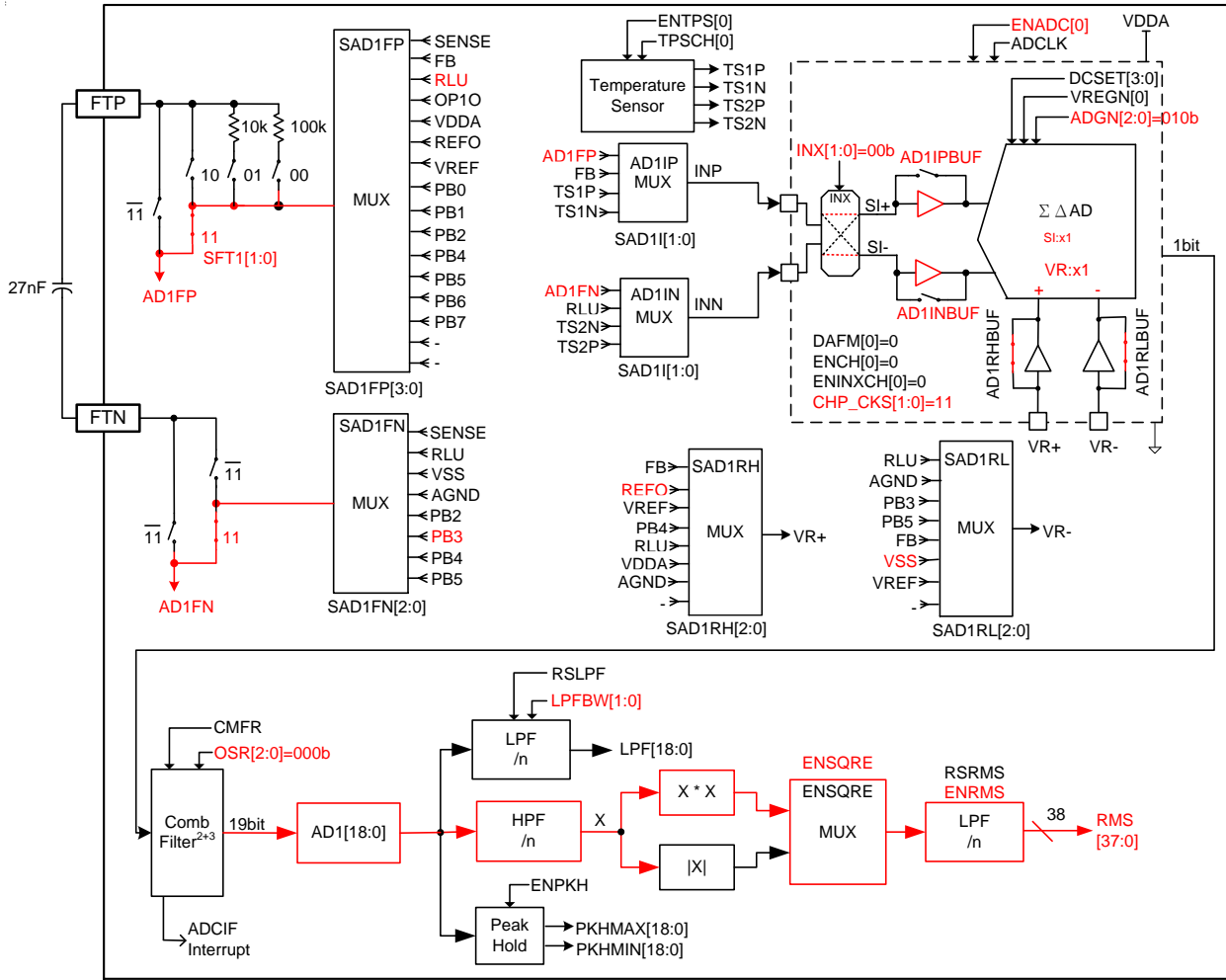

1.4. mV Function Power Supply Configuration

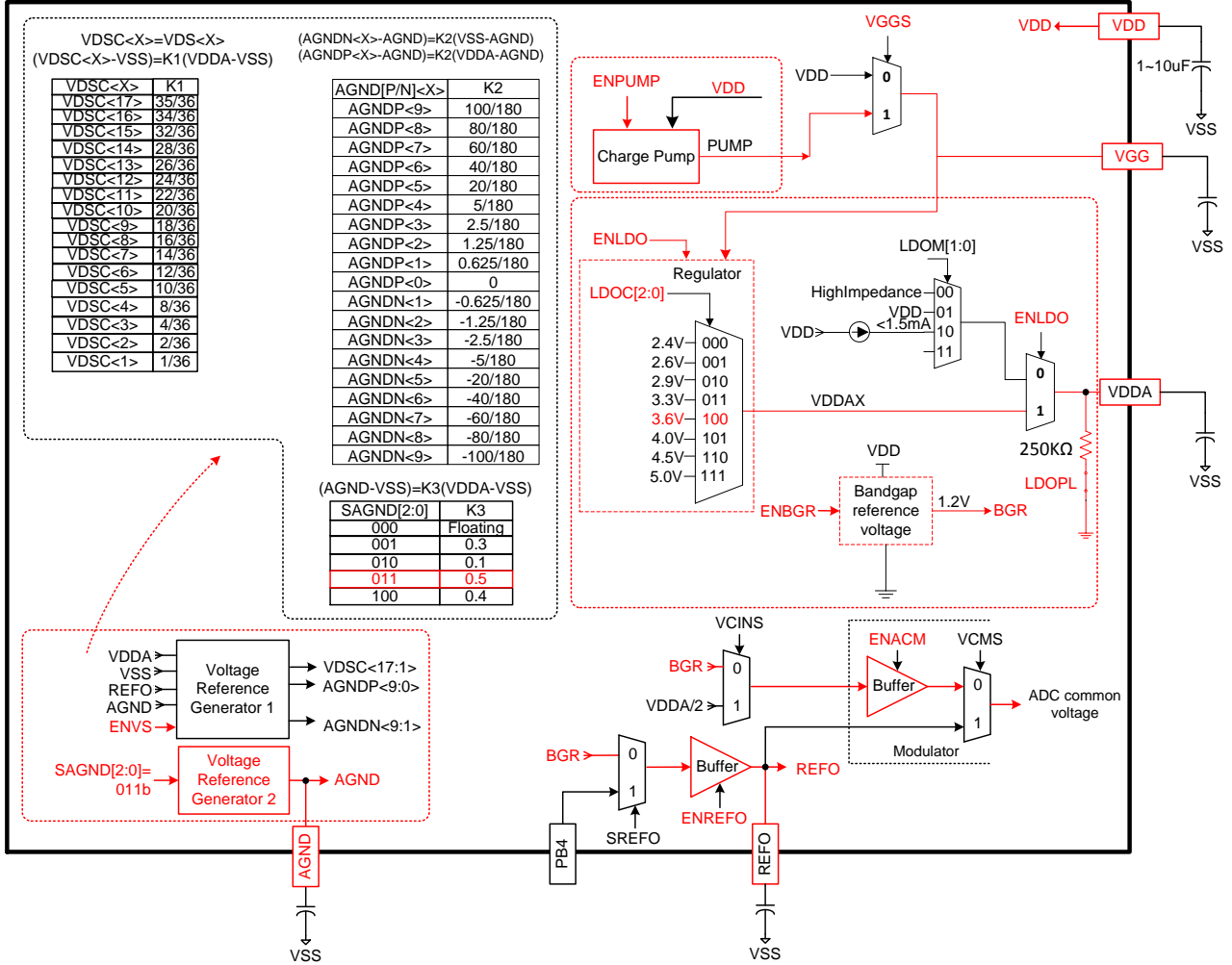

2. Current

Current measurement is similar with that of measuring mV. The difference is that in the Current measurement, there is a current-to-voltage resistance at the front end of the chip input. According to Ohm's law $V=I*R$, the greater the current, the greater the voltage drop on the resistance. The difference between μA , mA, and A measurement lies in the resistance of current to voltage, and the measured range of the chip is the same.

Current function will use ADC built-in programmable amplification (ADGN and VREGN) 8 times to increase gear selection.

The difference between DC and AC measurement is recommended to enable ADC Chopper function during DC measurement to reduce DC Offset and enable ADC Pre-Filter. On the contrary, it is not necessary to turn on Chopper in AC measurement.

2.1. Current Input Network Configuration

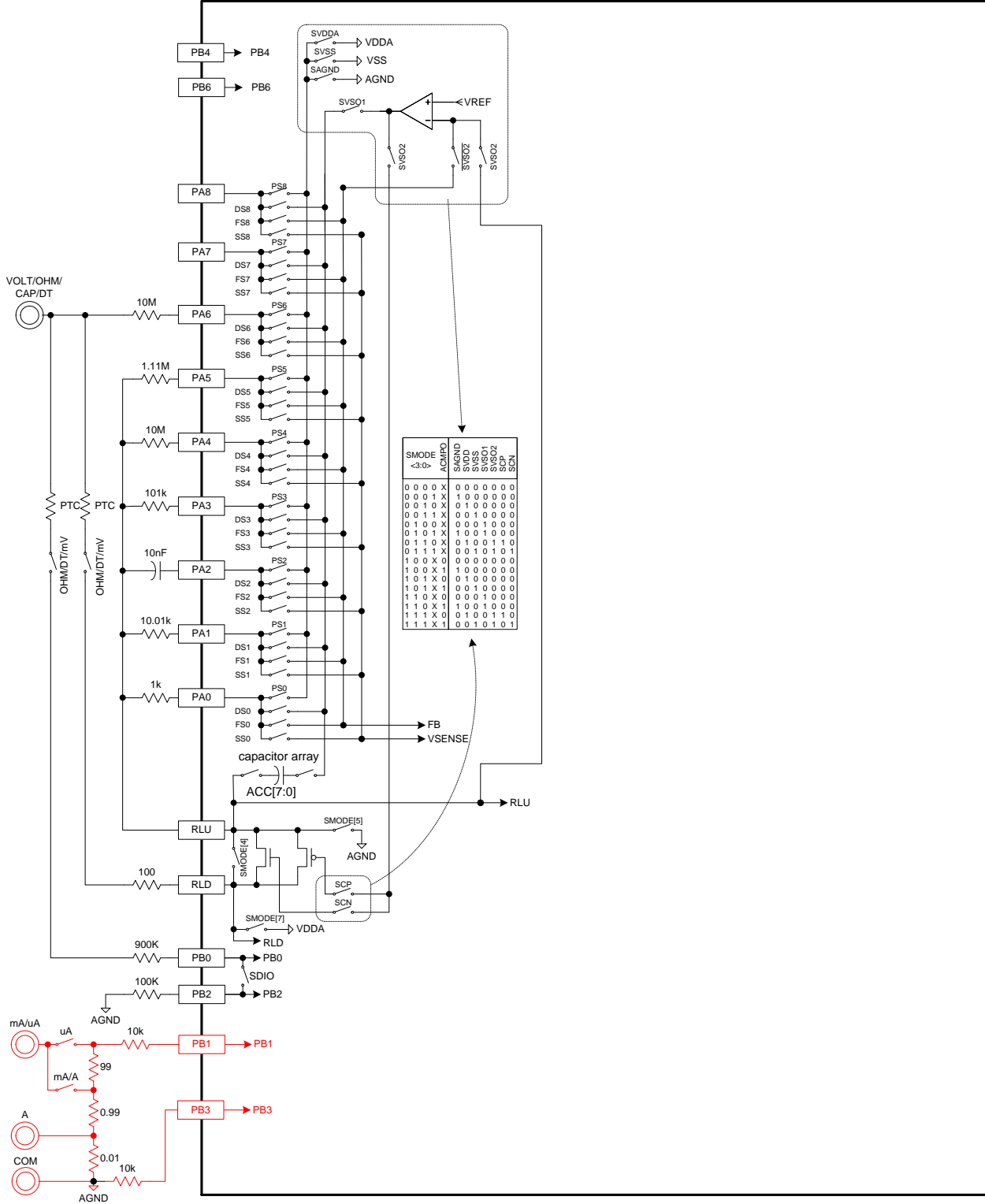

2.2. DC Current Measurement Network Configuration
2.2.1. ADC Settings(DC Lower Range)

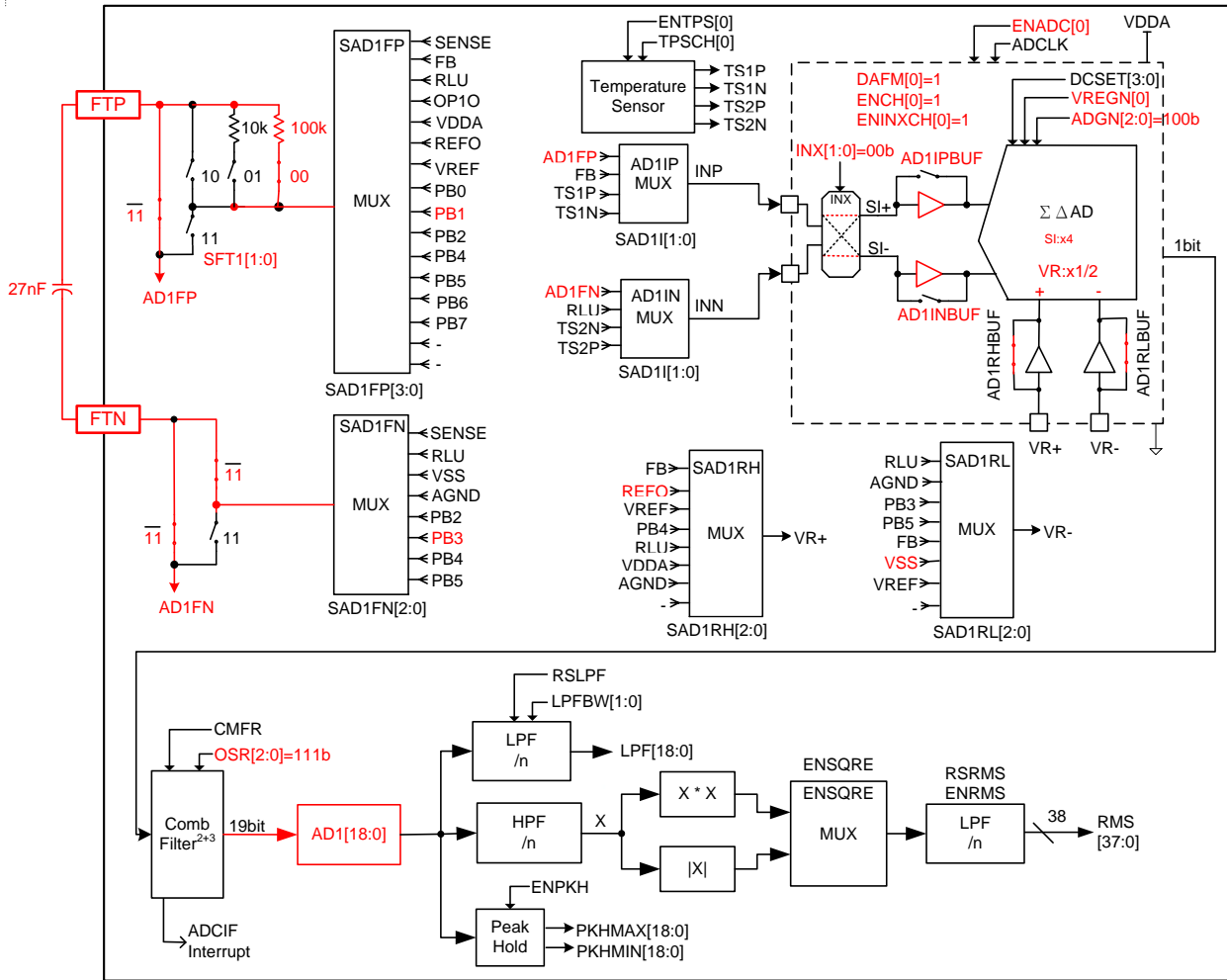

2.2.2. ADC Settings(DC Higher Range)

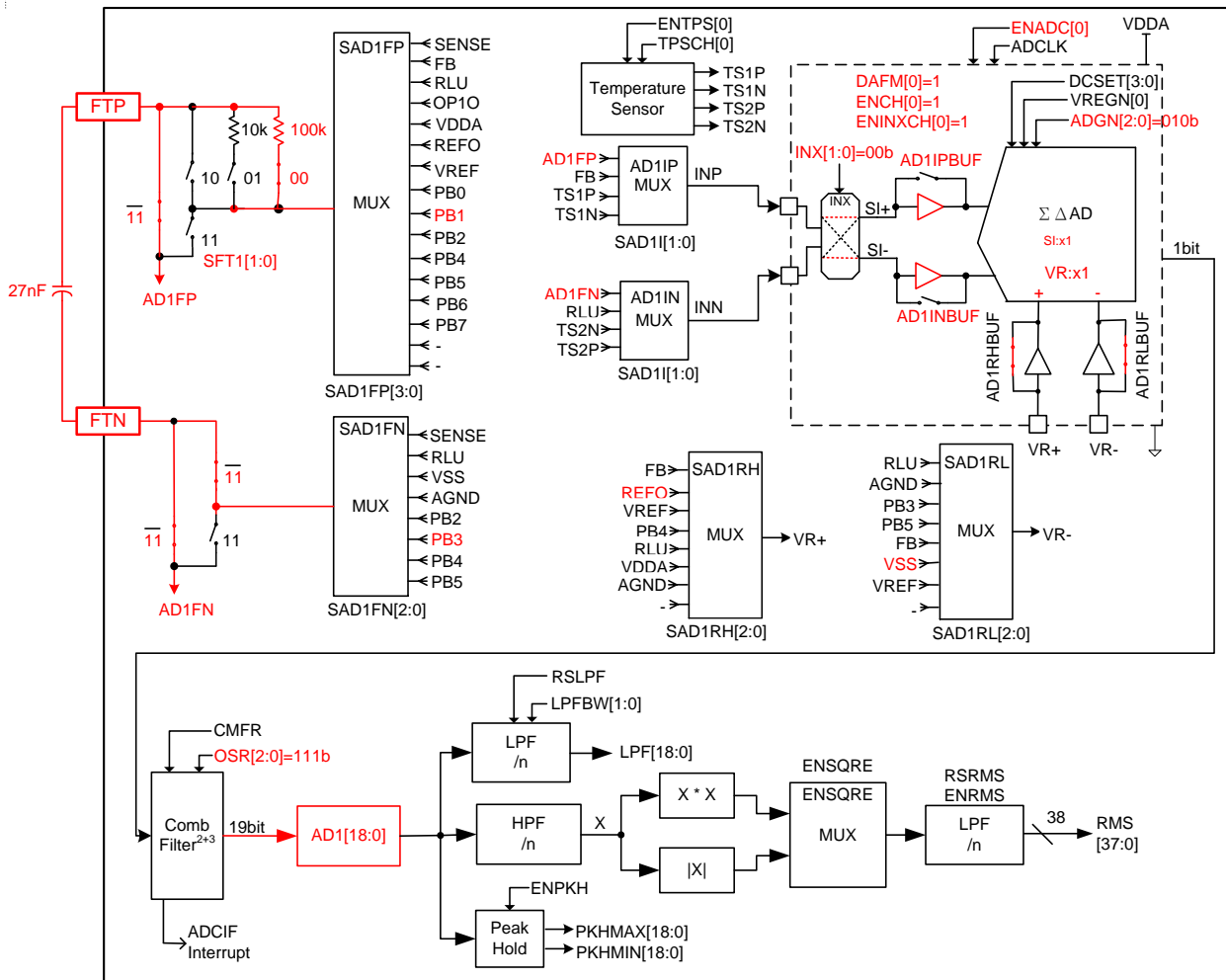

2.3. AC Current Measurement Network Configuration
2.3.1. ADC Settings(AC Lower Range)

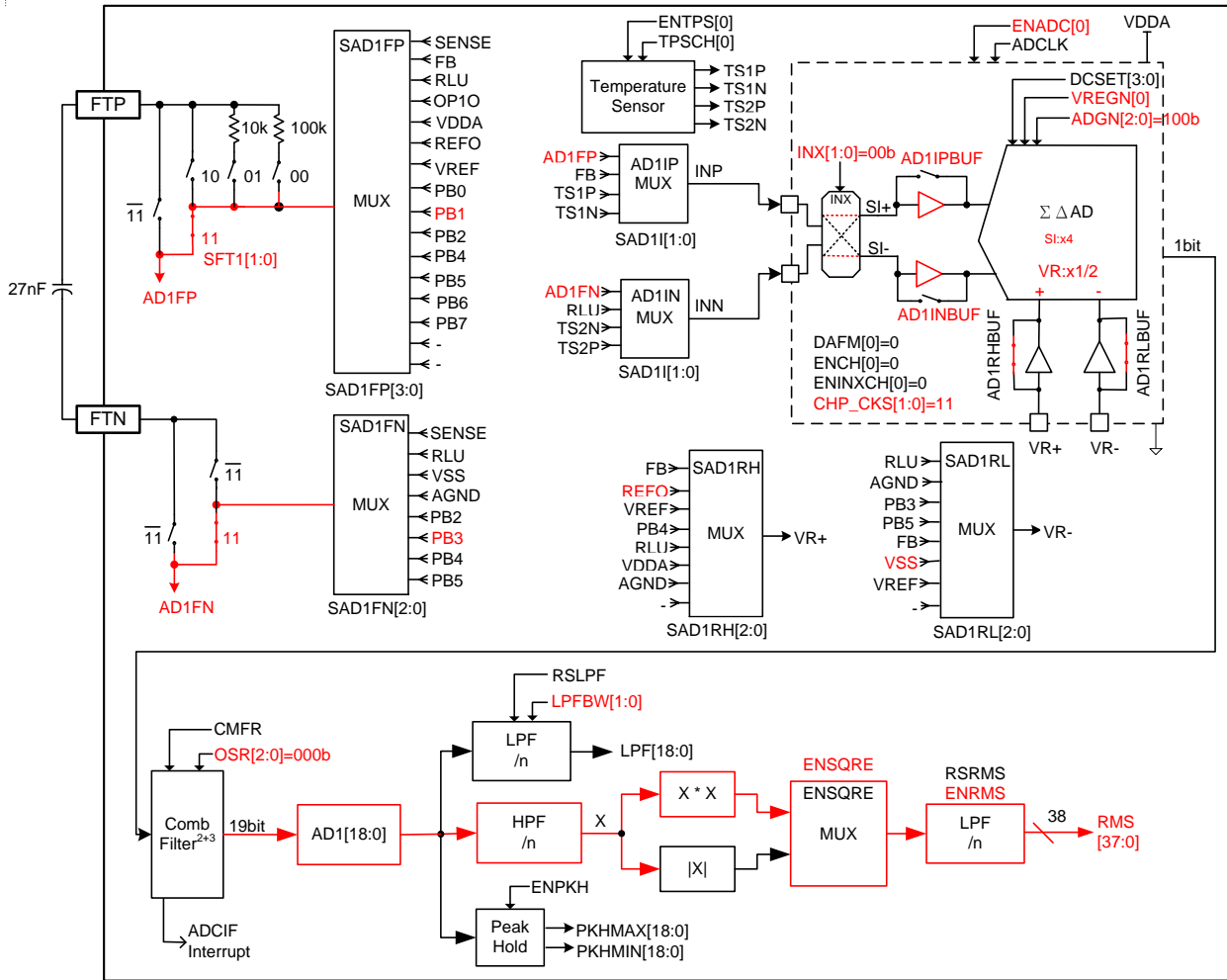

2.3.2. ADC Settings(AC Higher Range)

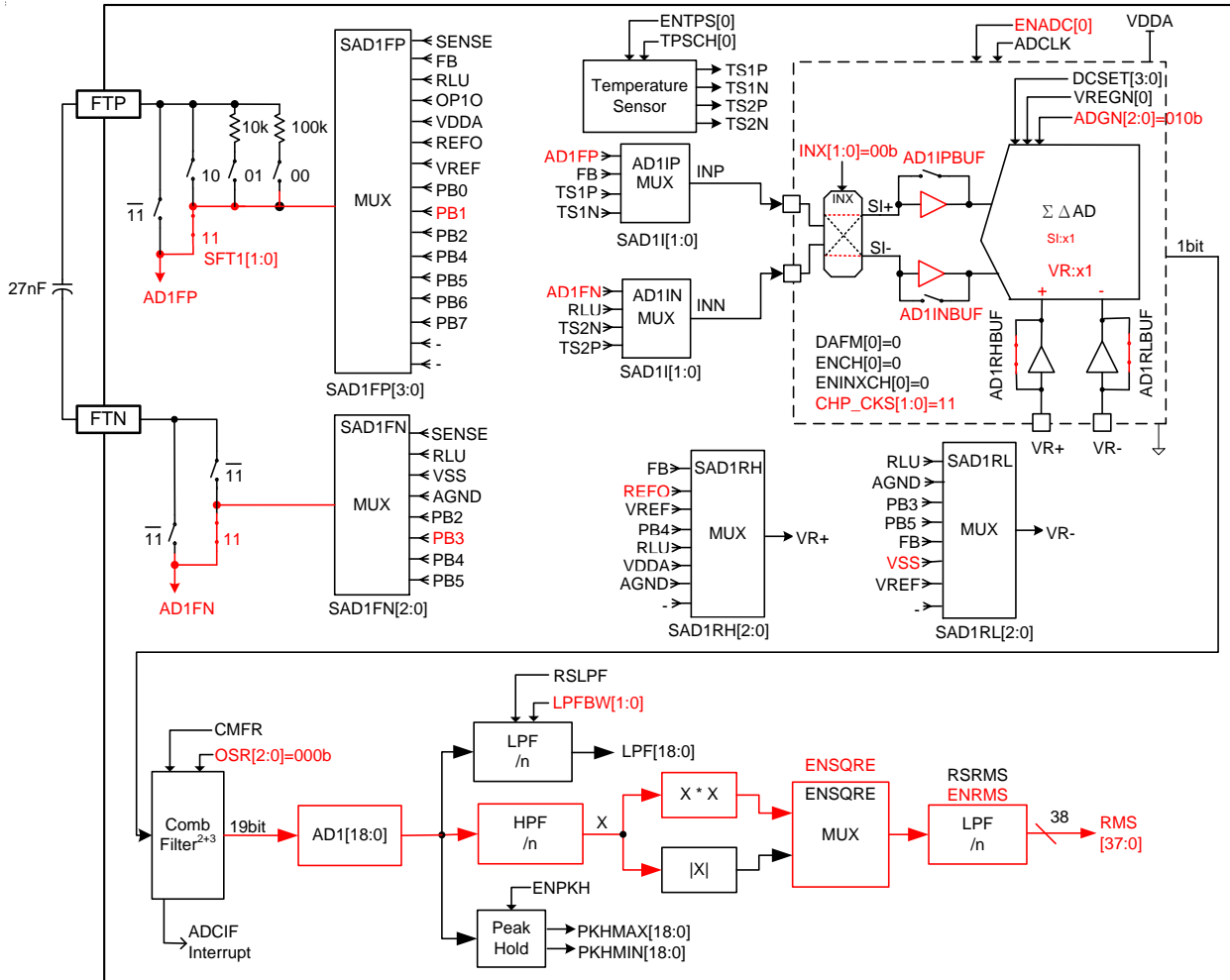

2.4. Current Function Power Supply Configuration

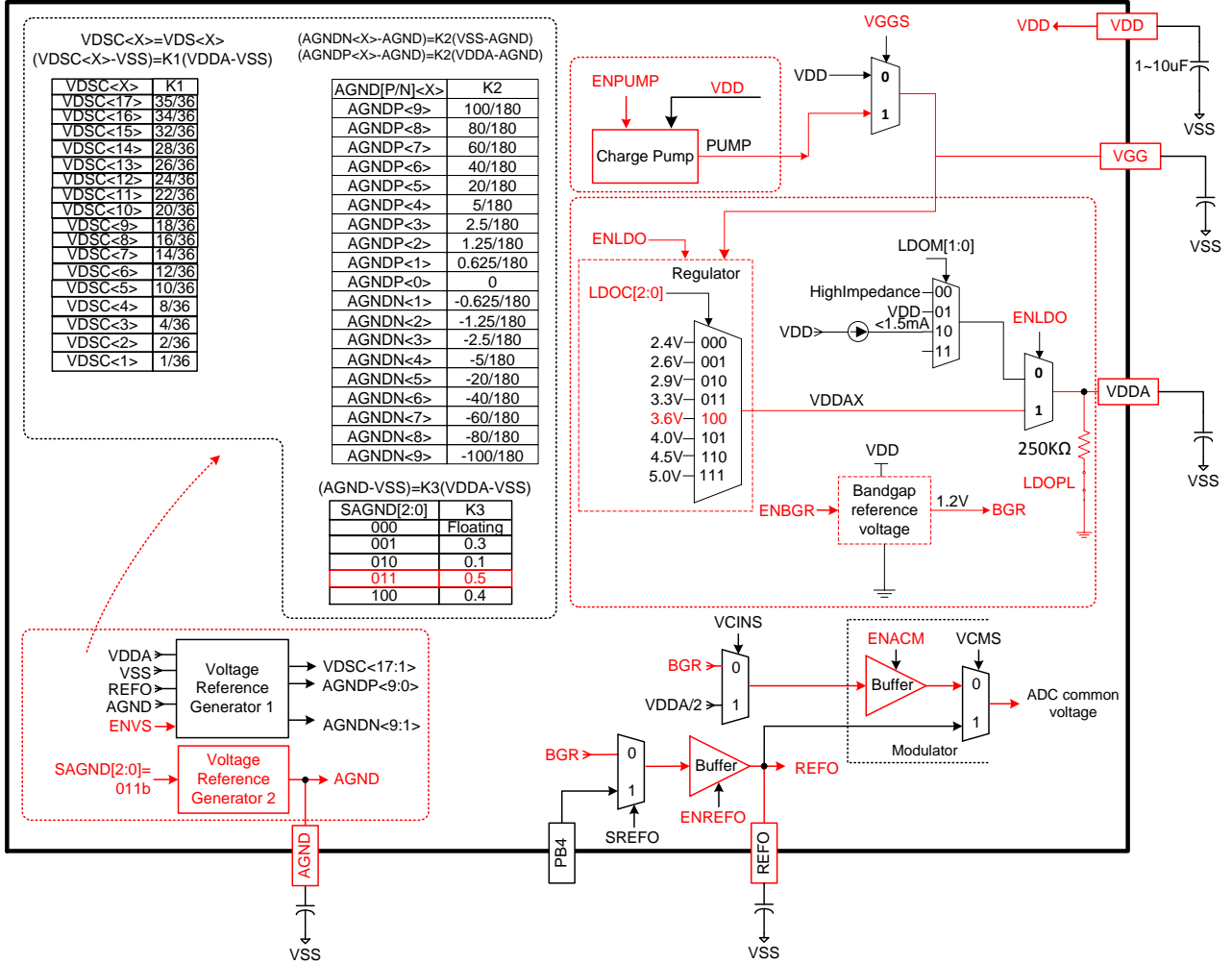

3. Voltage

The voltage measurement needs to be attenuated by 10~10000 times before the voltage signal enters the ADC measurement loop.

The input voltage division formula of AC/DC voltage file is as follows:

$$\begin{aligned}6V_{\text{Range}} &\Rightarrow V_{\text{in}} \times \frac{1.11\text{M}\Omega}{1.11\text{M}\Omega + 10\text{M}\Omega} = \frac{V_{\text{in}}}{10} \\60V_{\text{Range}} &\Rightarrow V_{\text{in}} \times \frac{101\text{k}\Omega}{101\text{k}\Omega + 10\text{M}\Omega} = \frac{V_{\text{in}}}{100} \\600V_{\text{Range}} &\Rightarrow V_{\text{in}} \times \frac{10\text{k}\Omega}{10\text{k}\Omega + 10\text{M}\Omega} = \frac{V_{\text{in}}}{1000} \\1000V_{\text{Range}} &\Rightarrow V_{\text{in}} \times \frac{1\text{k}\Omega}{1\text{k}\Omega + 10\text{M}\Omega} = \frac{V_{\text{in}}}{10000}\end{aligned}$$

The difference between DC and AC measurement is recommended to enable ADC Chopper function during DC measurement to reduce DC Offset and enable ADC Pre-Filter. On the contrary, it is not necessary to turn on Chopper in AC measurement.

3.1. 6V Input Network Configuration

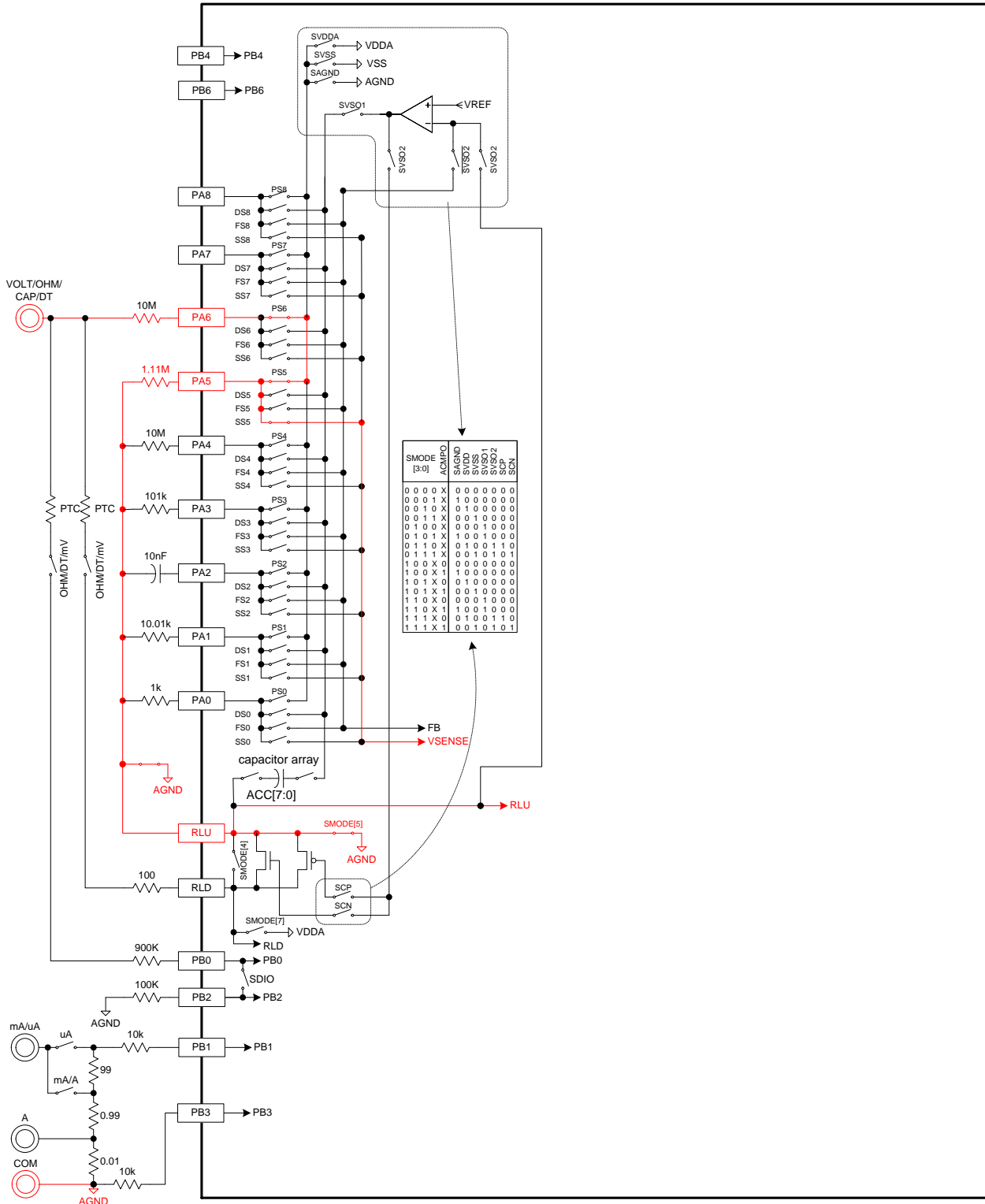

3.2. 60V Input Network Configuration

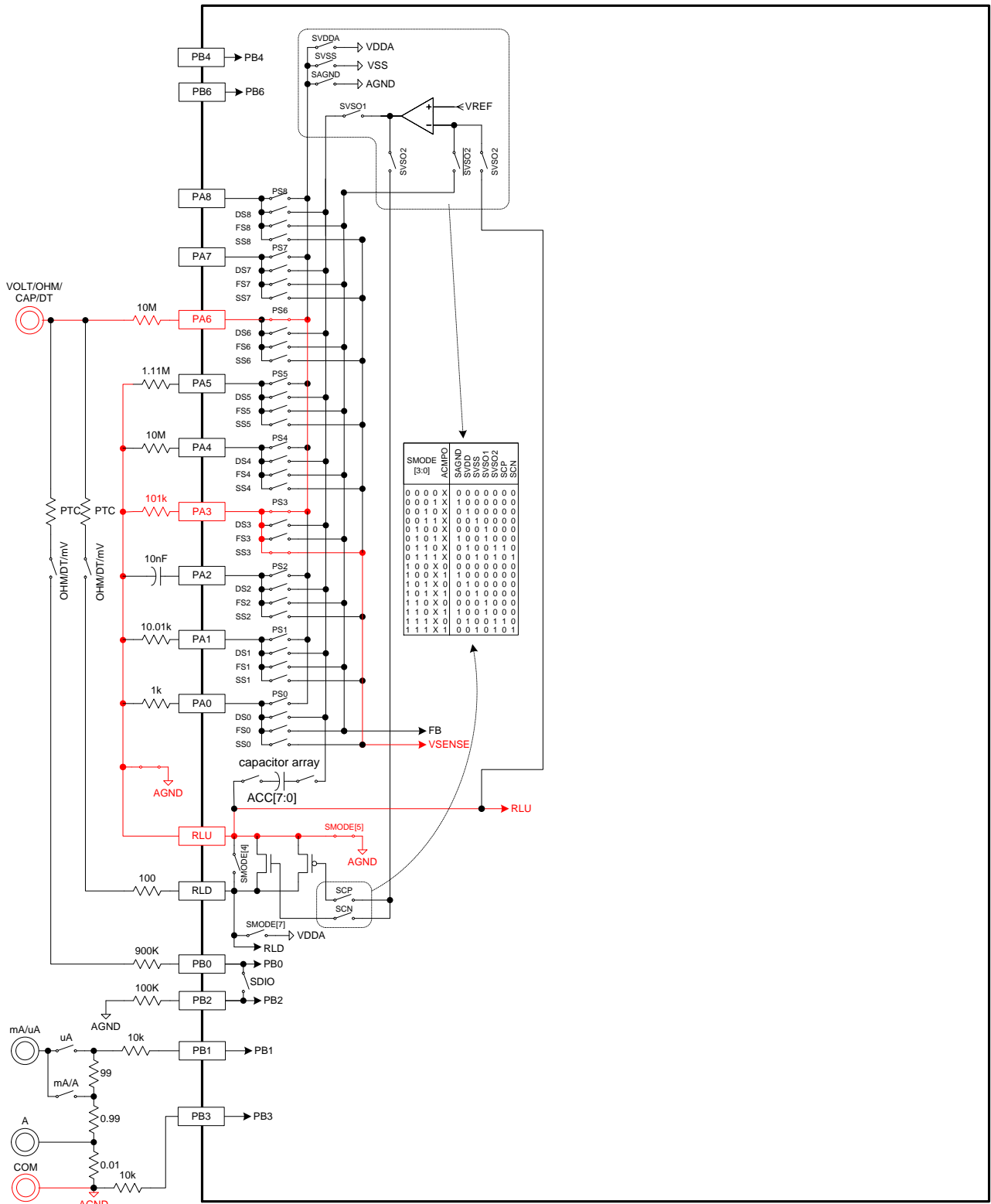

3.3. 600V Input Network Configuration

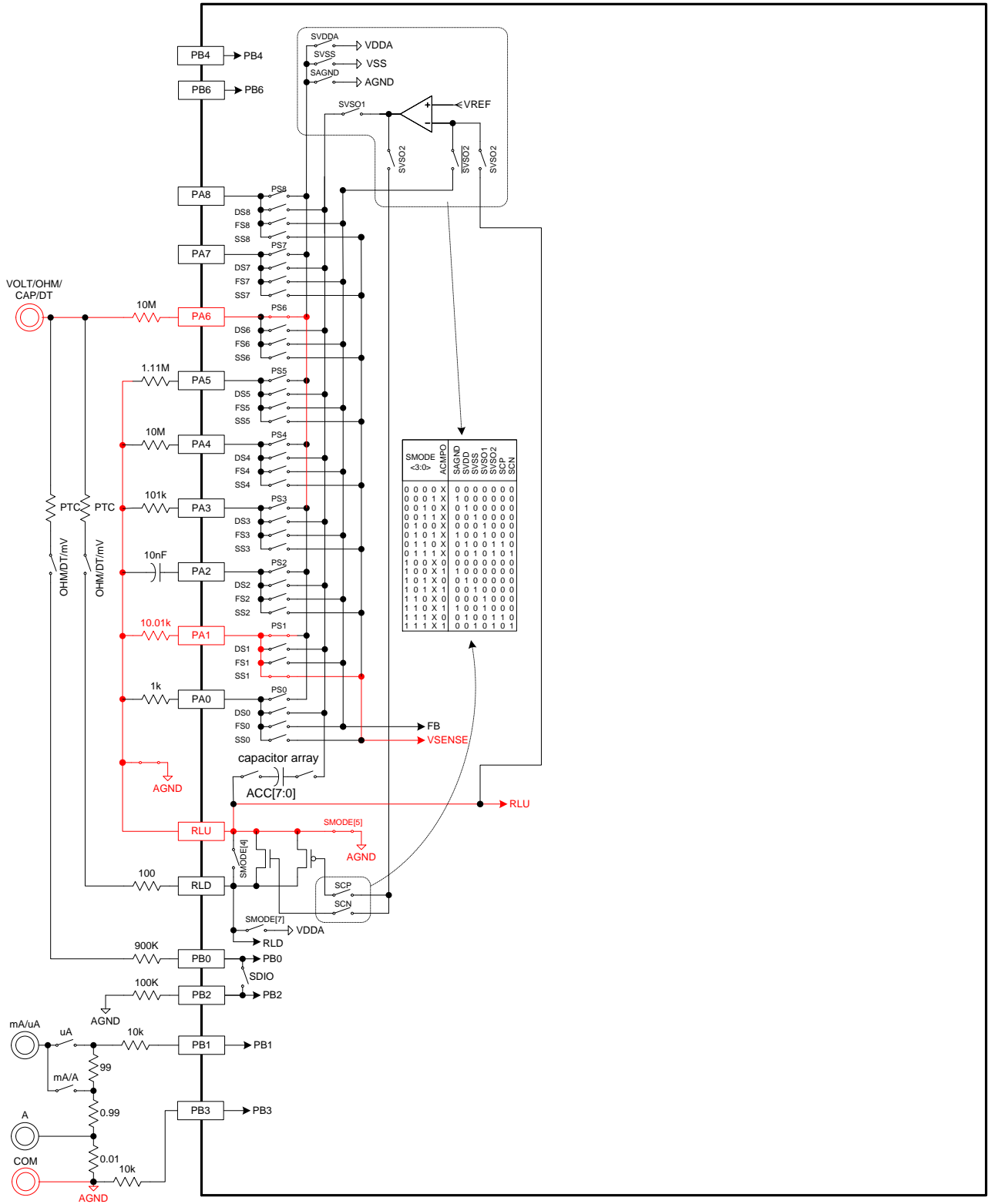

3.4. 1000V Input Network Configuration

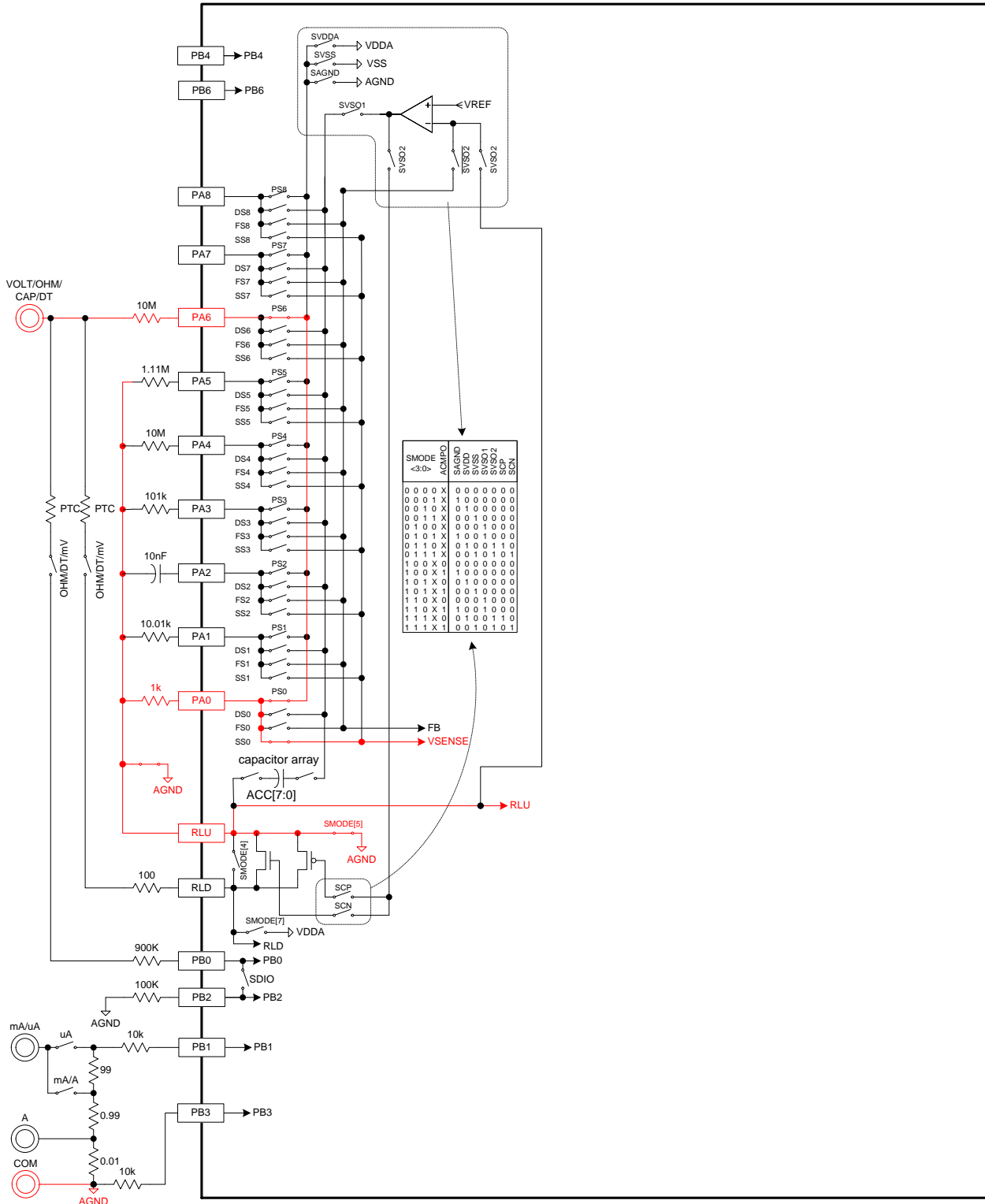

3.5. DCV Measurement Network Configuration

3.5.1. ADC Settings

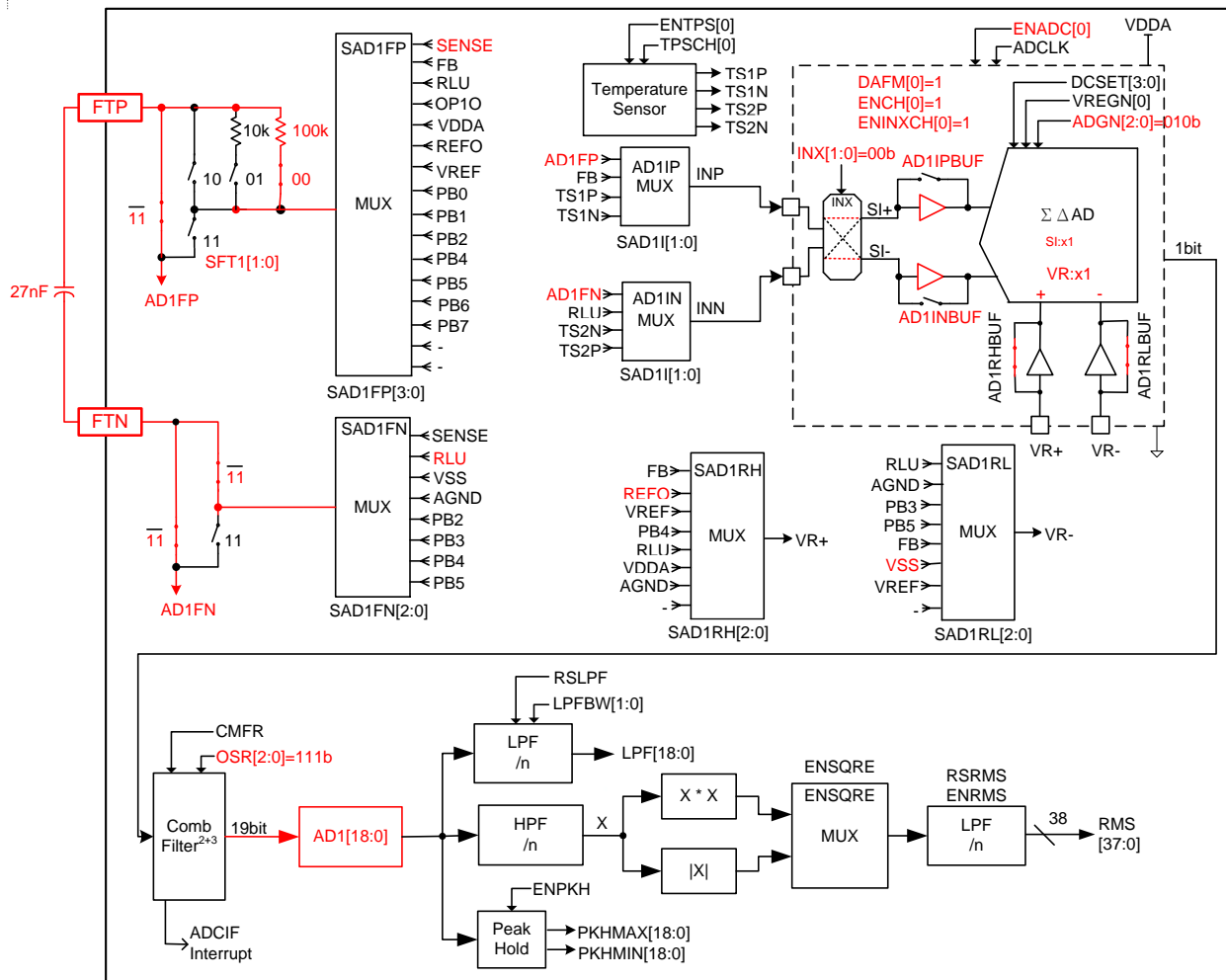

3.6. ACV Measurement Network Configuration
3.7. ADC Settings

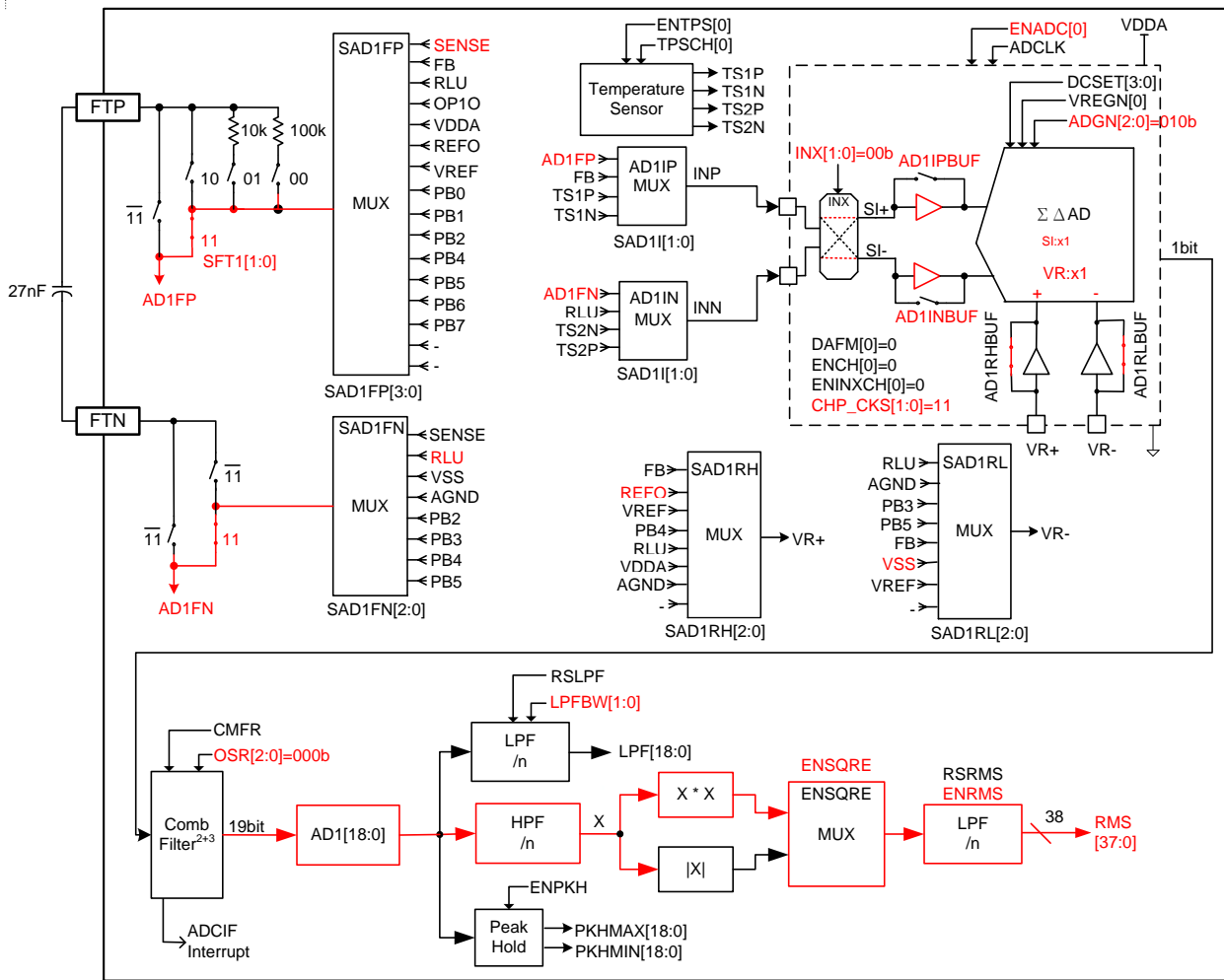

3.8. Voltage Function Power Supply Configuration

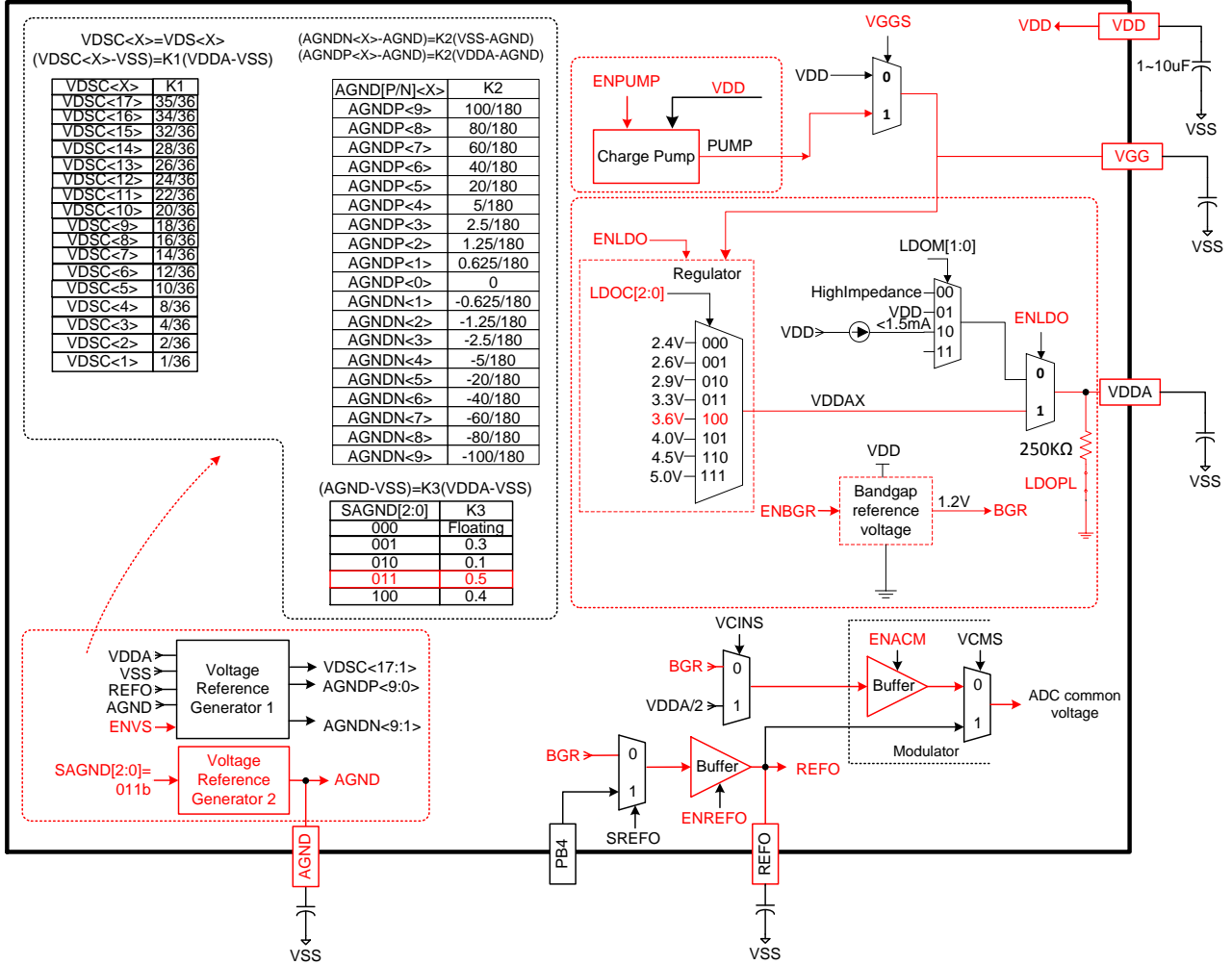

4. Resistor

The chip offers two ways to measure resistor, constant voltage and constant current measurement and different methods lead to diverse results. If the VREF used for output is AGNP or AGNDN, the ADC reference voltage must be REFO; otherwise, if the VREF used is VDSC, the ADC reference voltage must be VDPA.

Constant voltage or ratio resistor measurement, the formula is as follows:

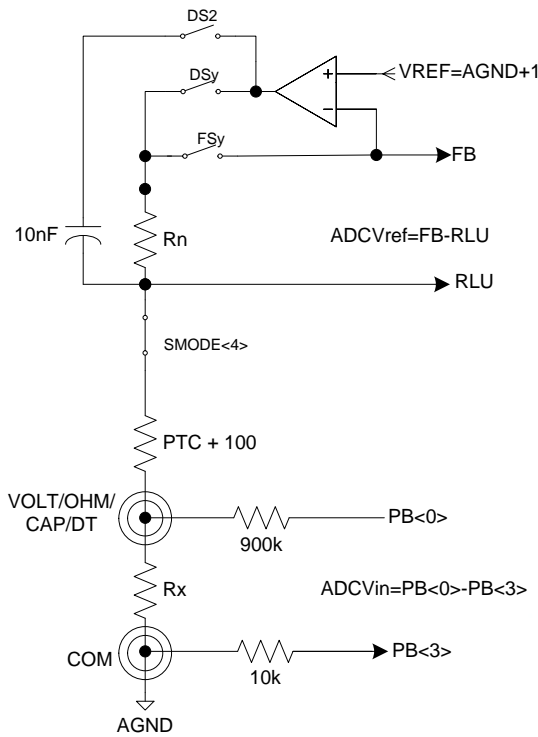

$$I_{Rx} = I_{Rn}$$

$$V_{Rx} = I_{Rx} \times R_x = \frac{V_{Rn}}{R_n} \times R_x$$

$$R_{Read} = \frac{V_{Rx}}{V_{Rn}} \times \text{Full Scale}$$

$$R_{Read} = \frac{ADC_{V_{in}}}{ADC_{V_{ref}}} \times \text{Full Scale}$$

Constant current measurement, the formula is as follows:

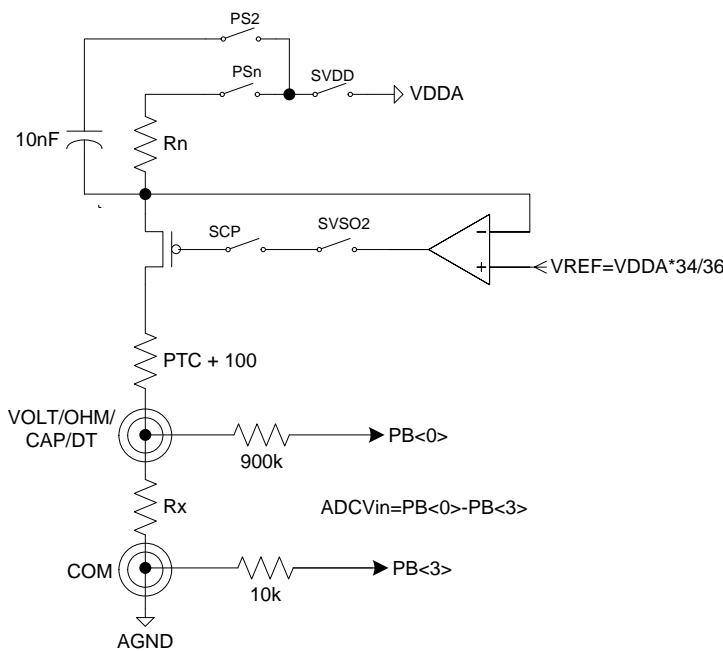

$$I_{Rx} = I_{Rn} = \frac{VDDA - VREF}{R_n}$$

$$R_{Read} = \frac{ADC_{V_{in}}}{ADC_{V_{ref}}} \times \text{Full Scale}$$

$$R_{Read} = \frac{R_x \times I_{Rx}}{ADC_{V_{ref}}} \times \text{Full Scale}$$

4.1. 600Ω Input Network Configuration

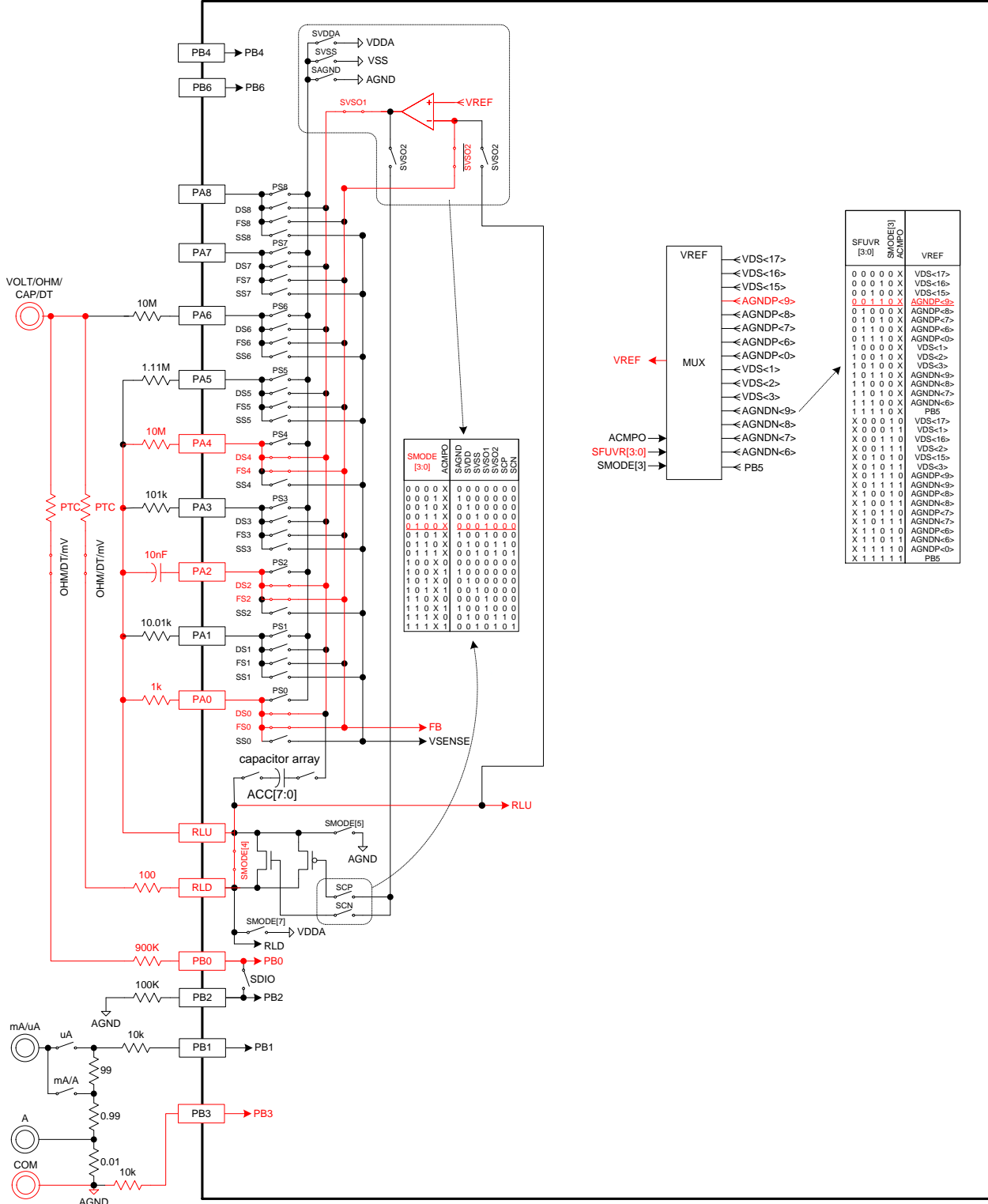

4.2. 6kΩ Input Network Configuration

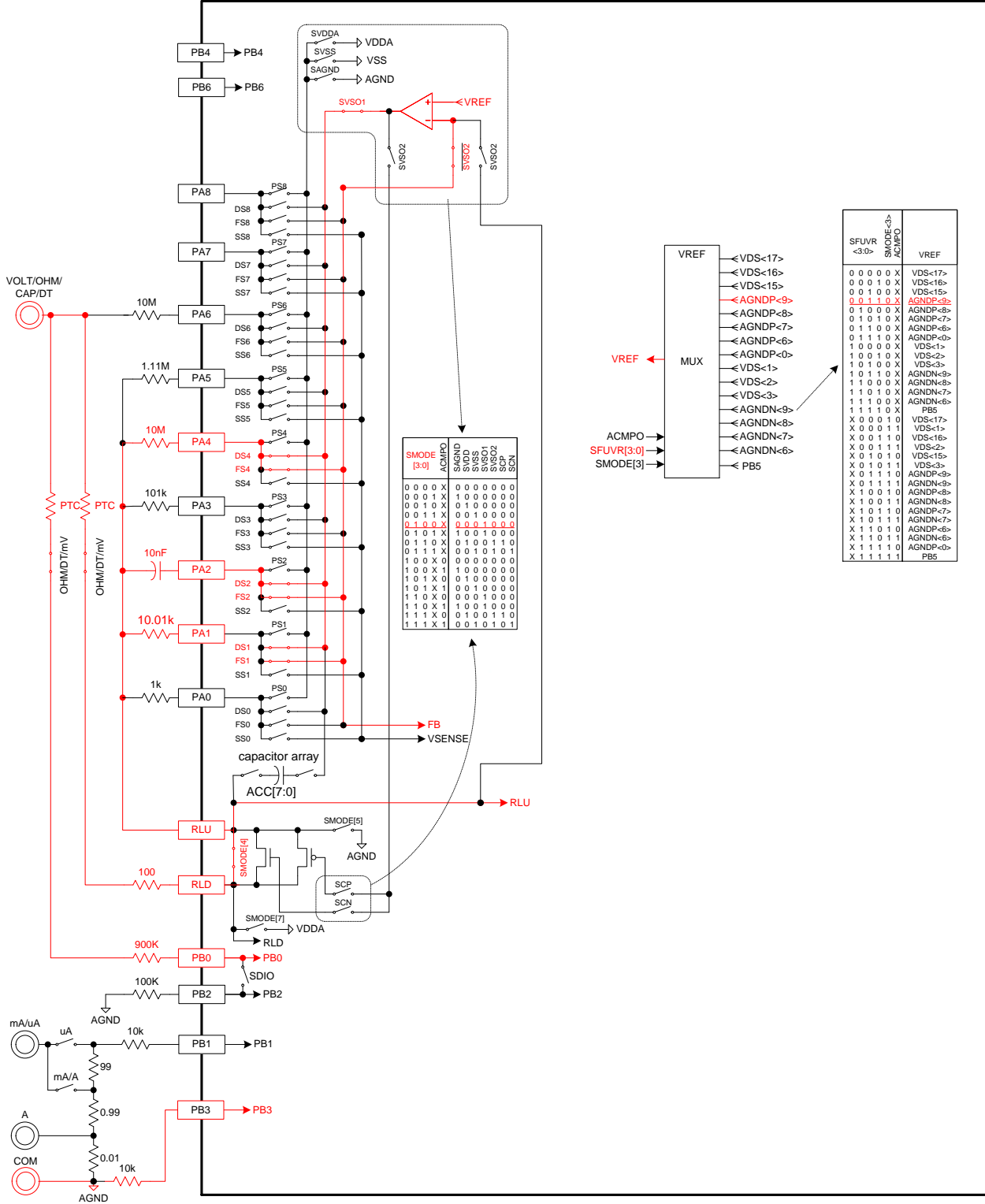

4.3. 60k Ω Input Network Configuration

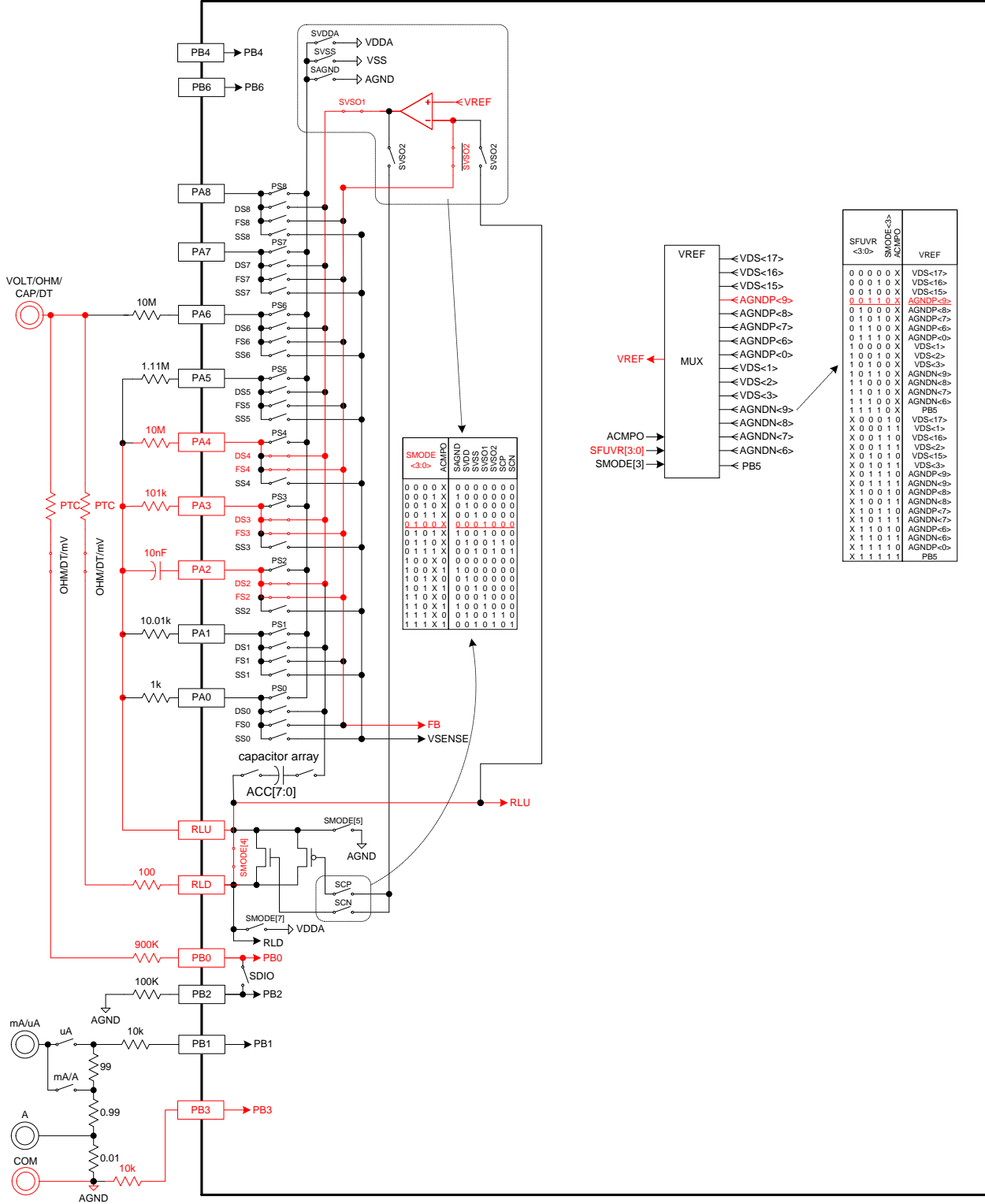

4.4. 600Ω~60kΩ Measurement Network Configuration

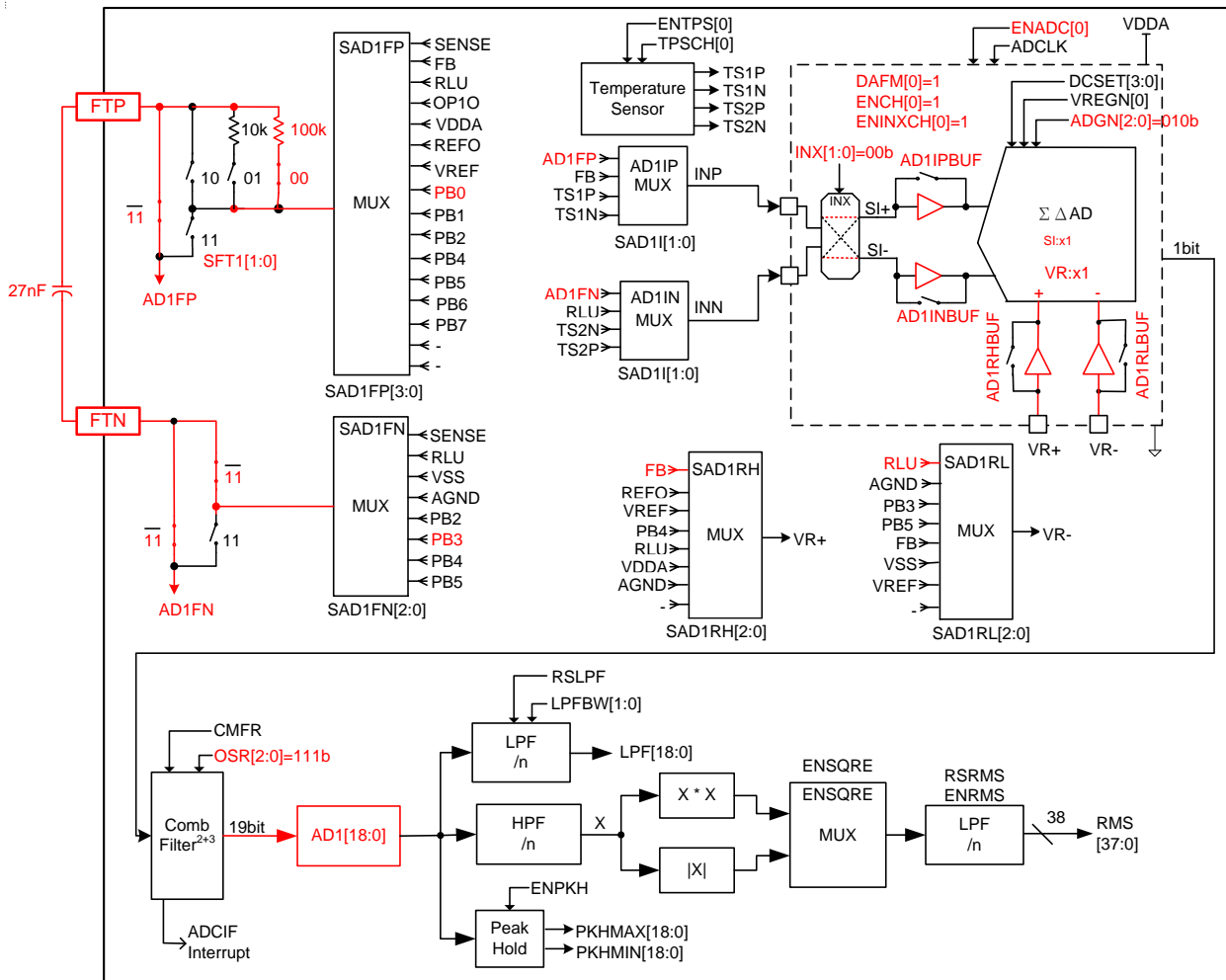

4.5. 600kΩ Input Network Configuration

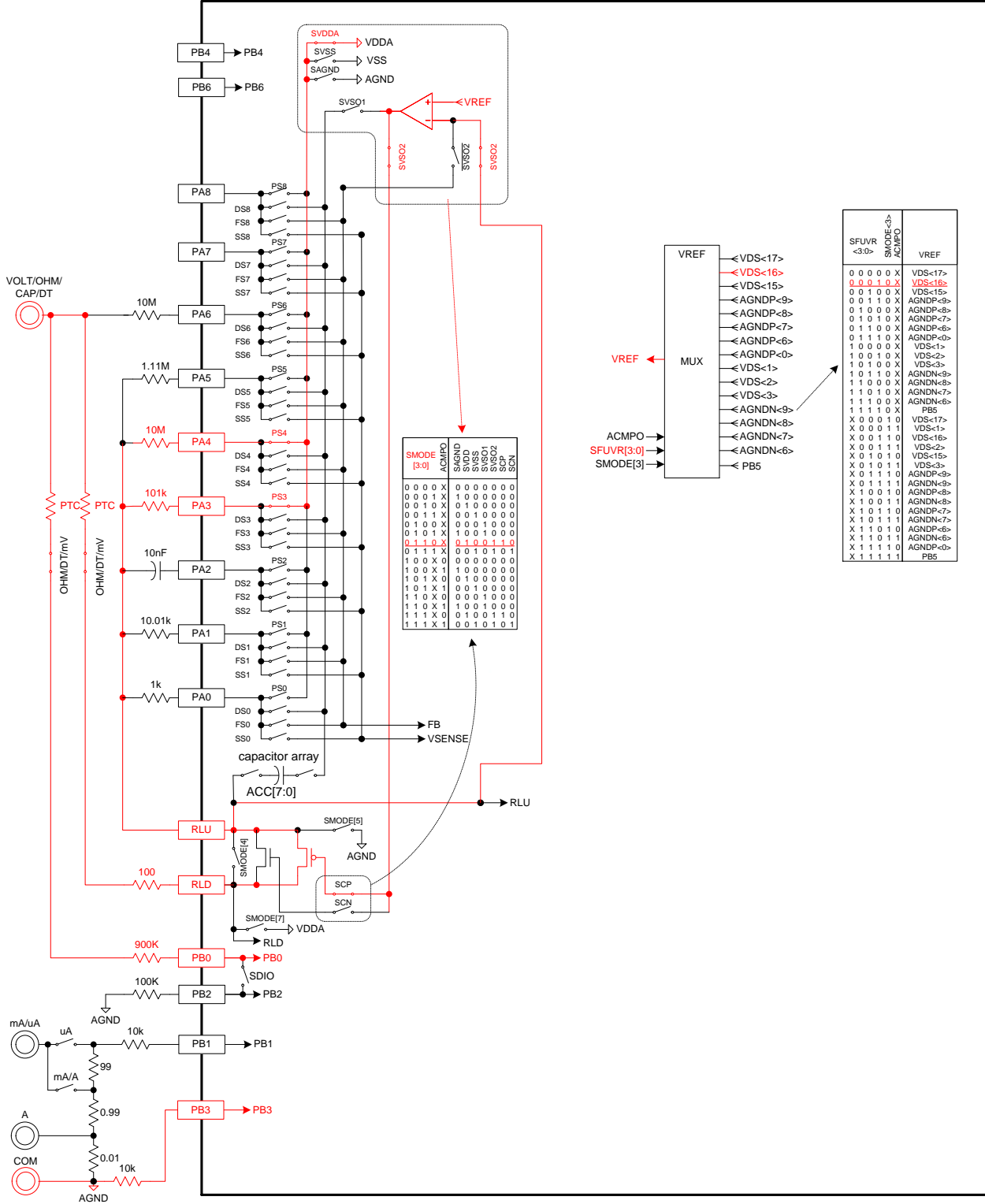

4.6. 6MΩ Input Network Configuration

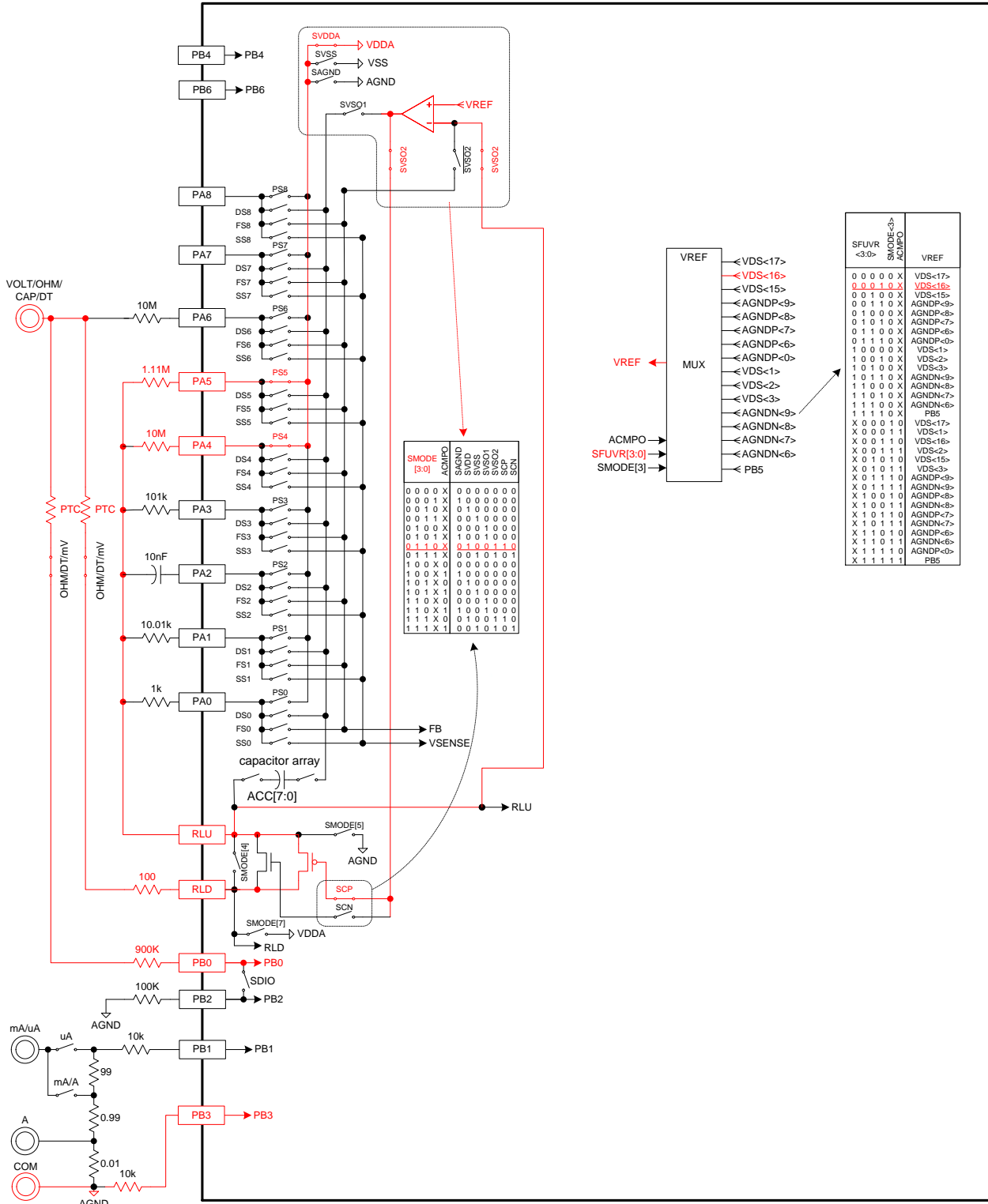

4.7. 60MΩ Input Network Configuration

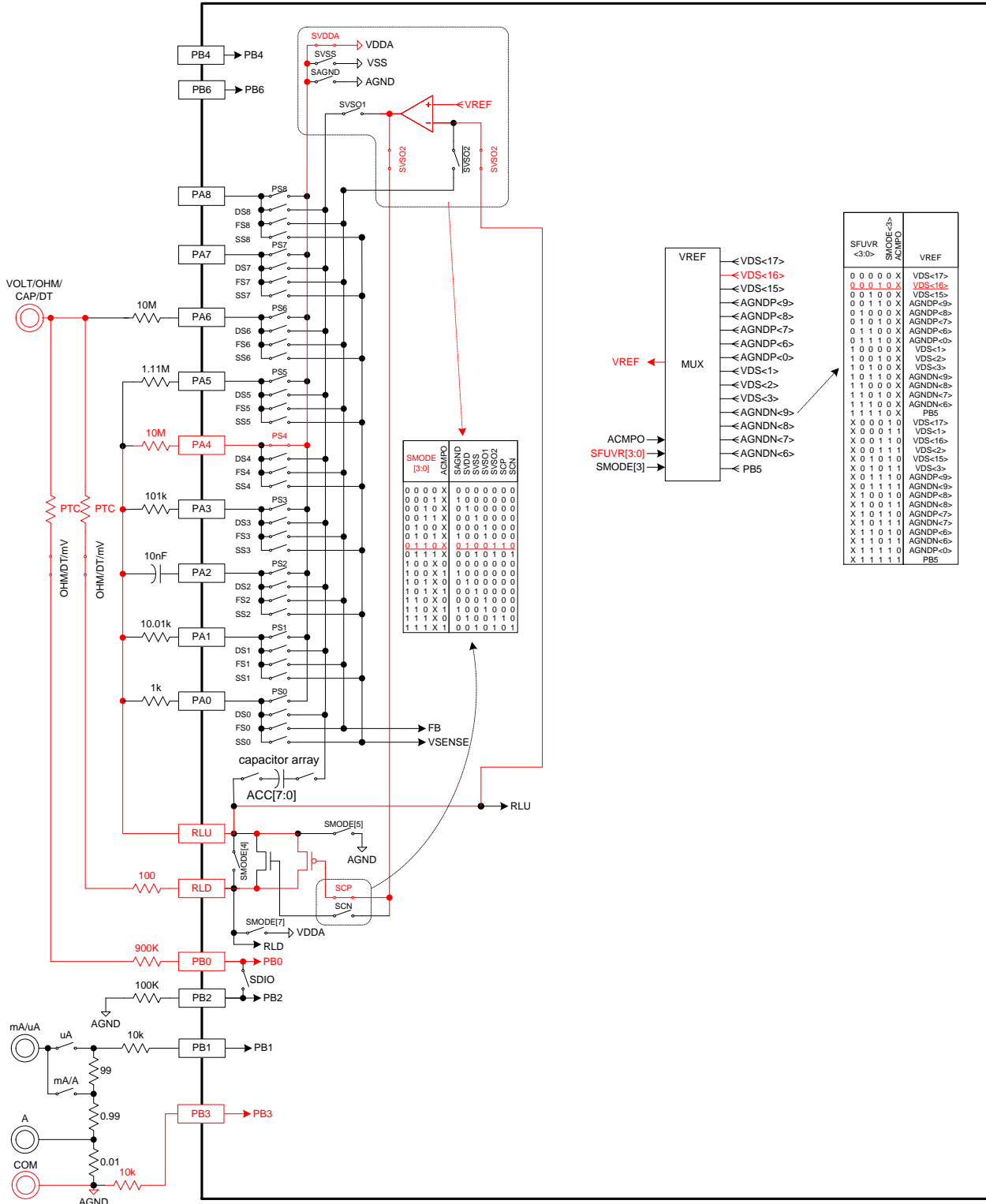

4.8. 600kΩ~60MΩ Measurement Network Configuration

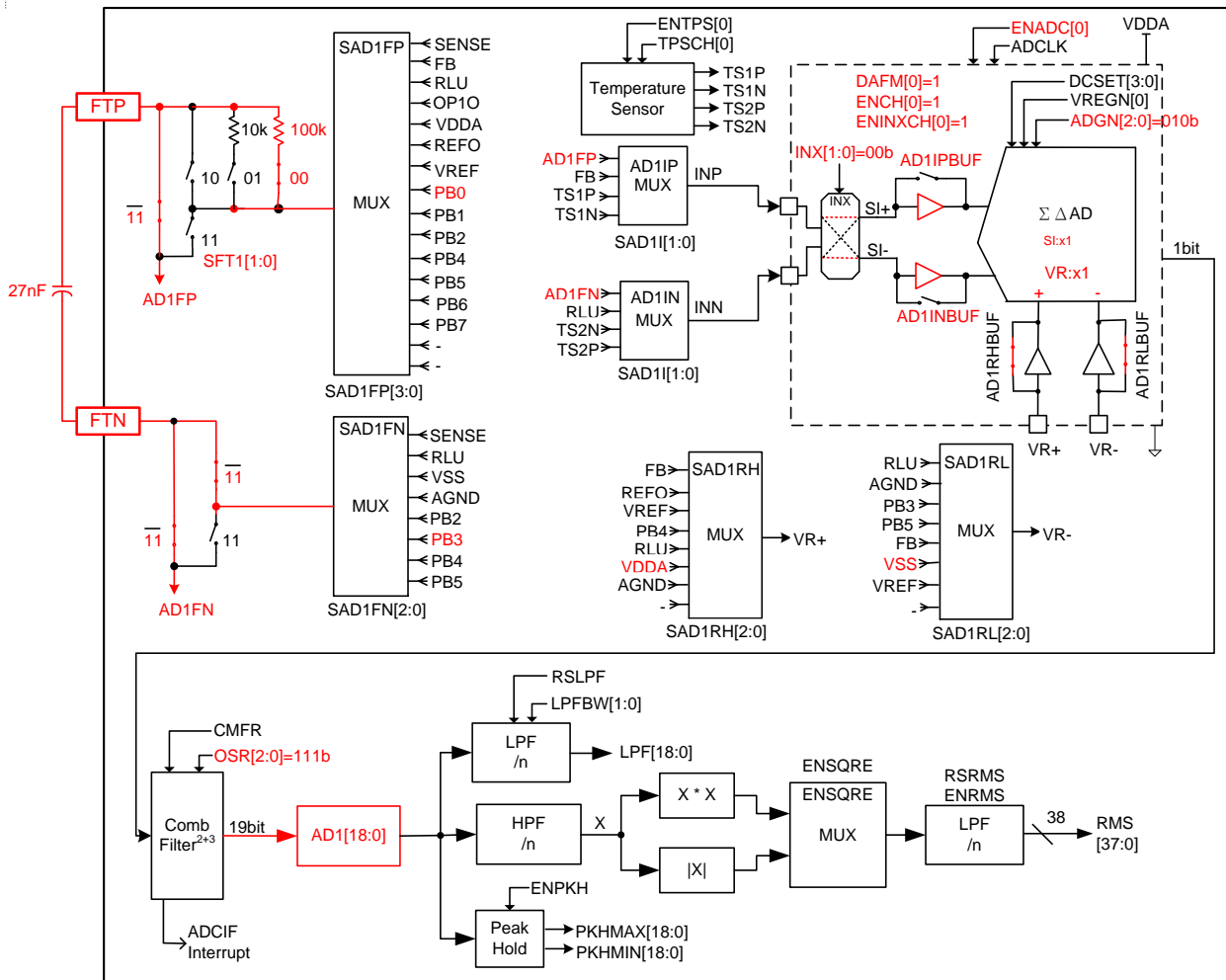

4.9. Resistor Function Power Supply Configuration

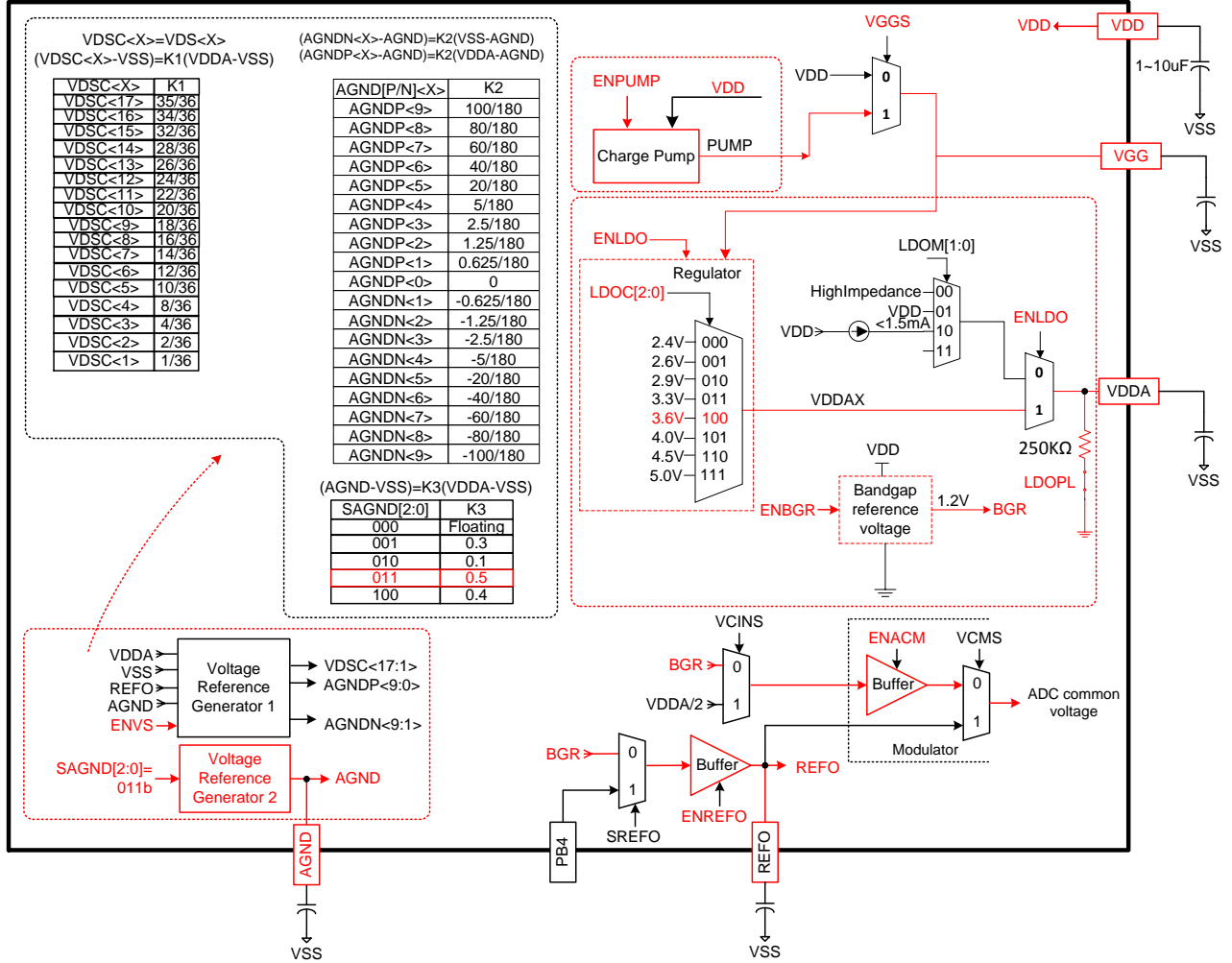

5. Continuity

Can use constant current or constant voltage output measurements. This case is positive constant voltage output measurement.

5.1. Continuity Input Network Configuration

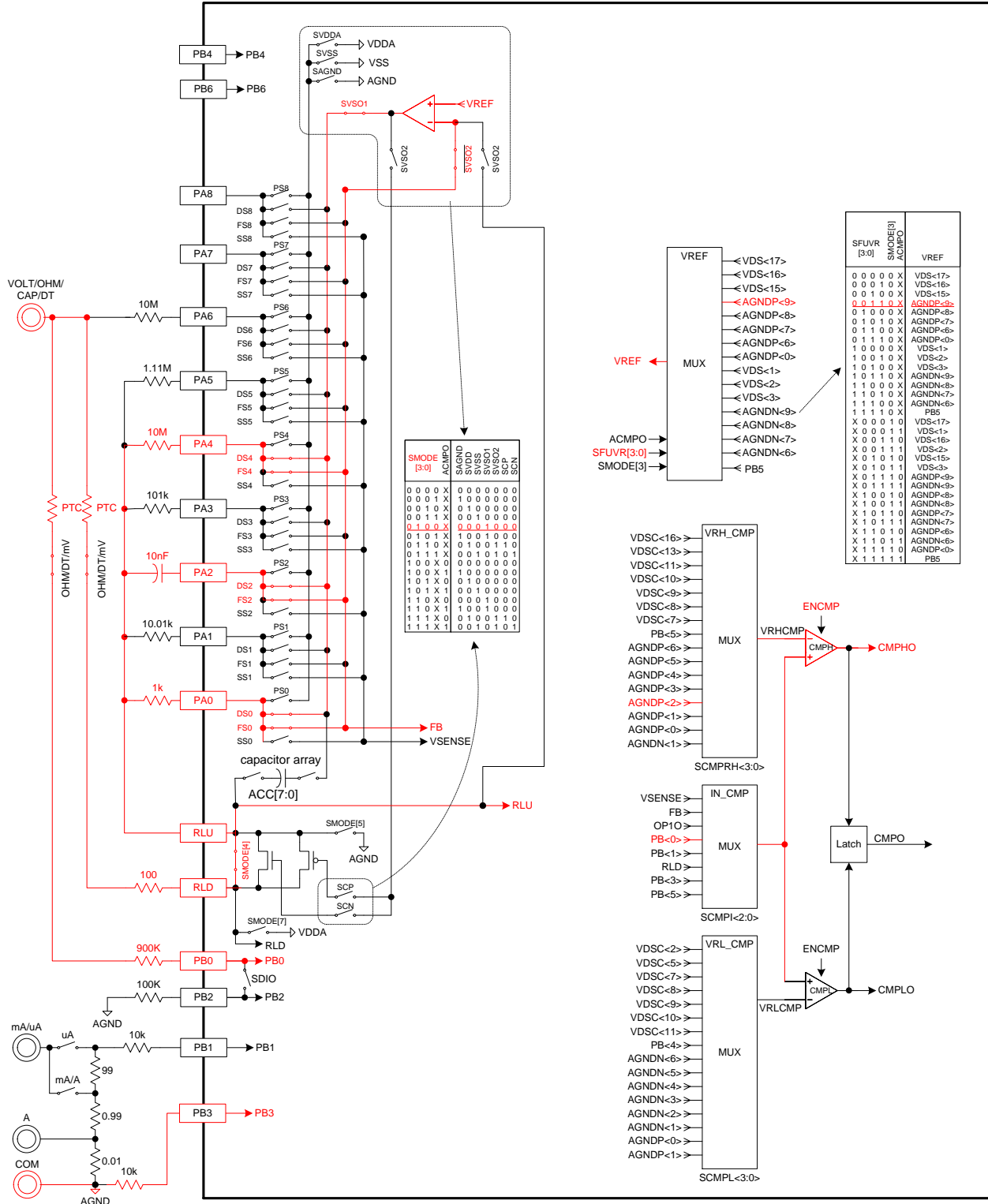

5.2. Continuity Measurement Network Configuration

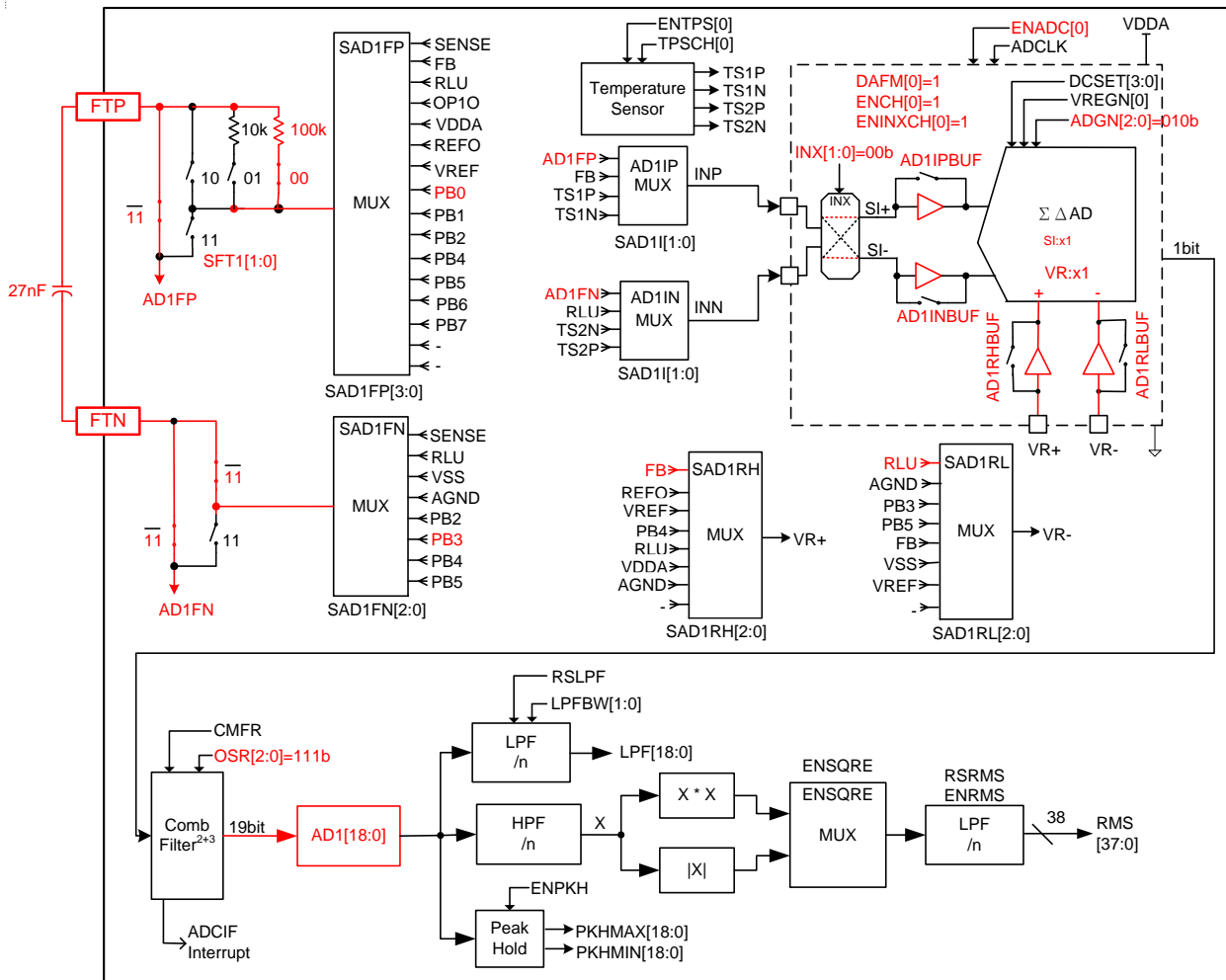

5.3. Continuity Function Power Supply Configuration

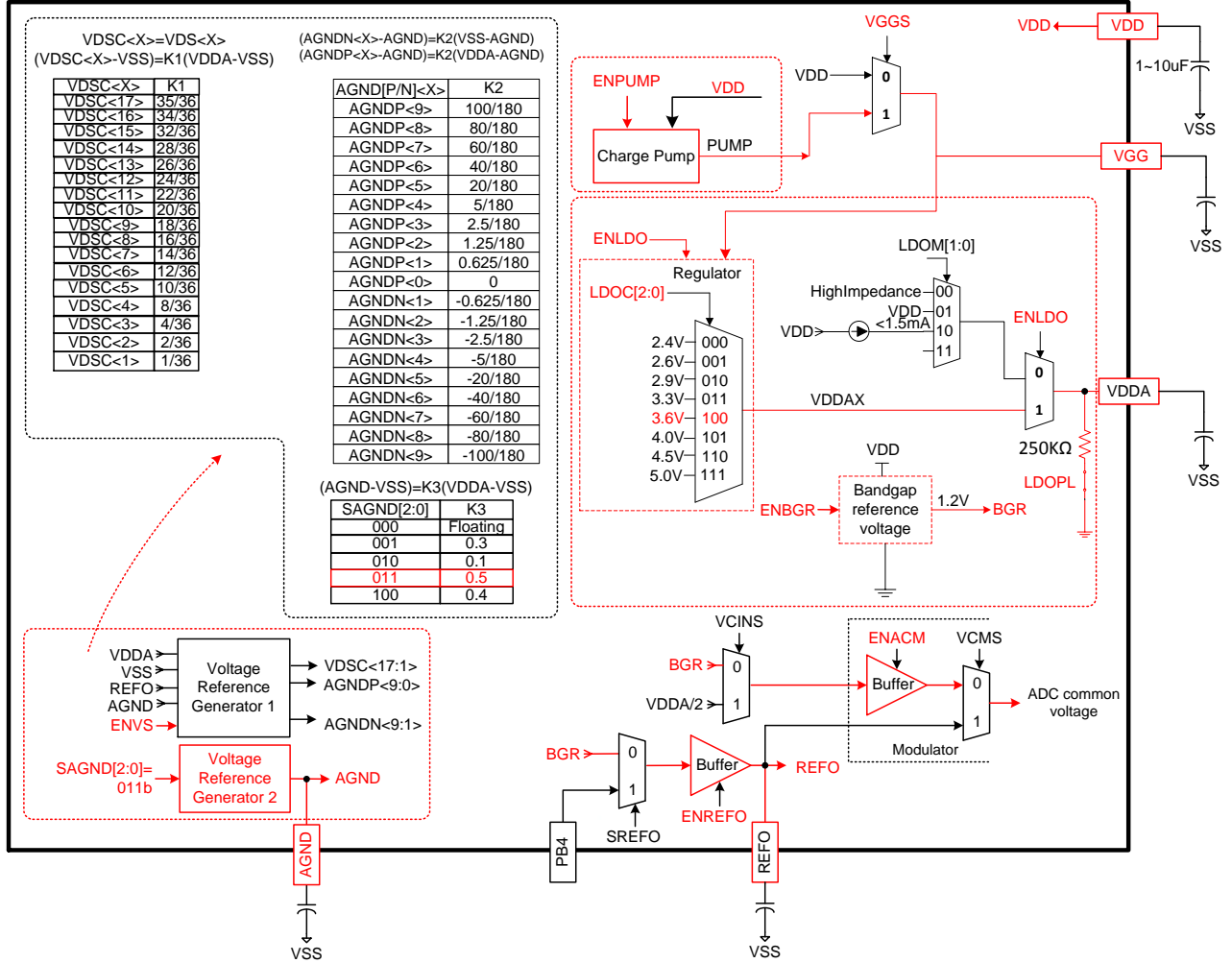

6. Diode

Diode function is to measure Forward Voltage or called PN Barrier Potential. This chip offers positive/negative constant current source or positive/negative constant voltage source measurement.

When constant current passed through diode, both edges of component will have voltage difference. The voltage is around 0.2V~1.5V, to prevent exceeding full scale. Thus, taking 900k Ω and 100k Ω to form 10 times attenuation.

6.1. Diode Input Network Configuration 6.1.1. Positive Constant Voltage Source Network Configuration

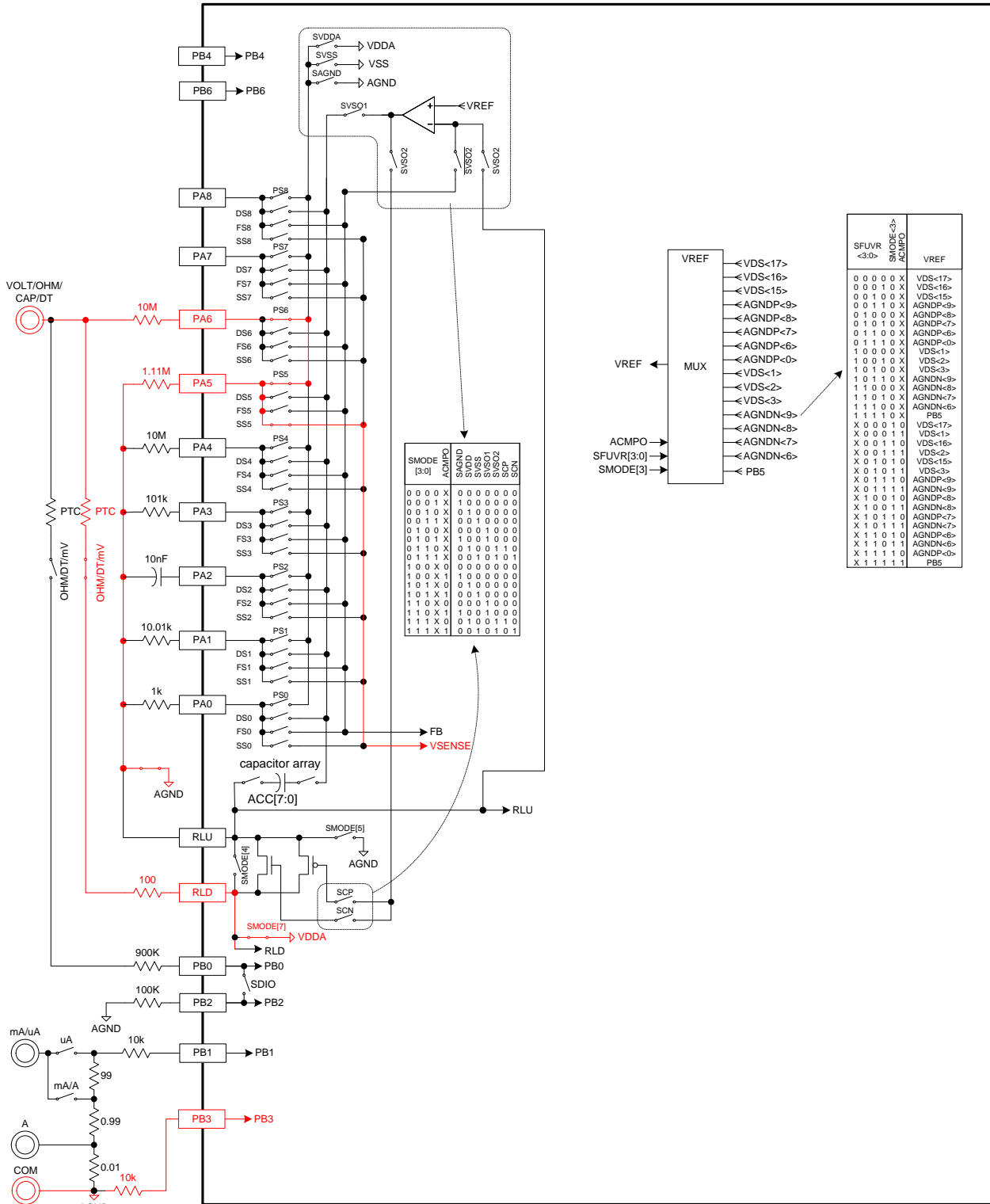

6.1.2. Positive Constant Current Source Network Configuration

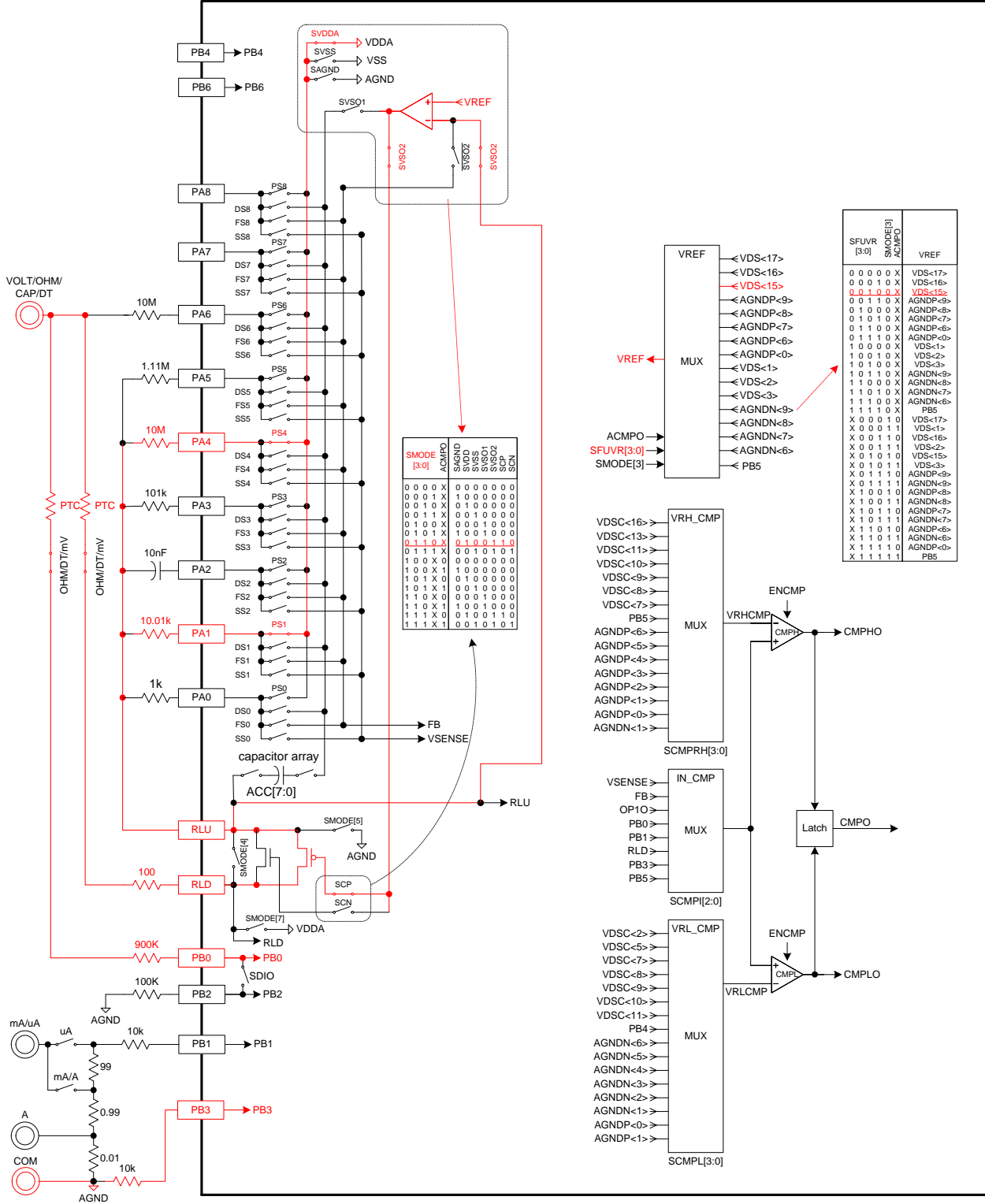

6.2. Diode Measurement Network Configuration
6.2.1. Positive Constant Voltage Source Measurement

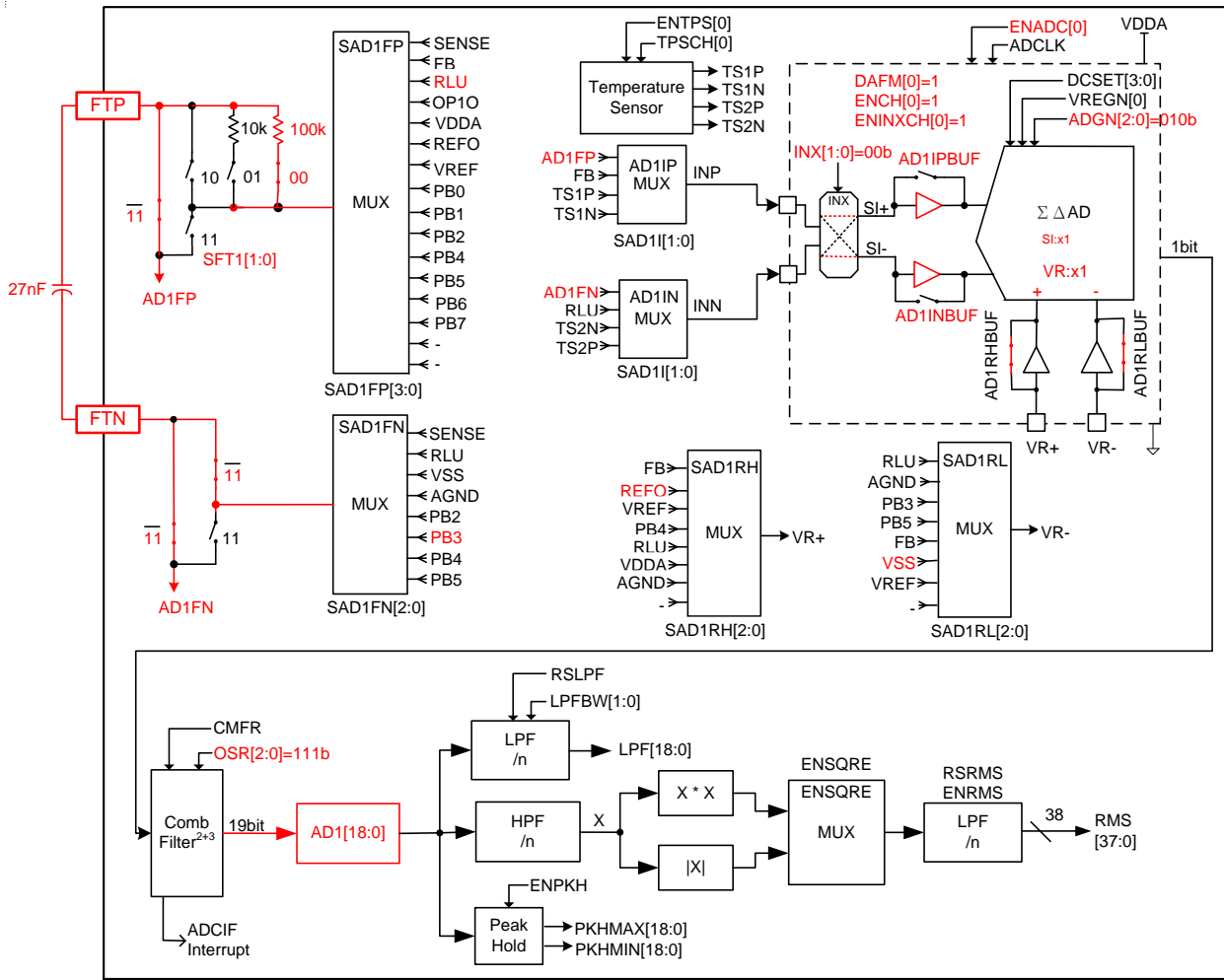

6.2.2. Positive Constant Current Source Measurement

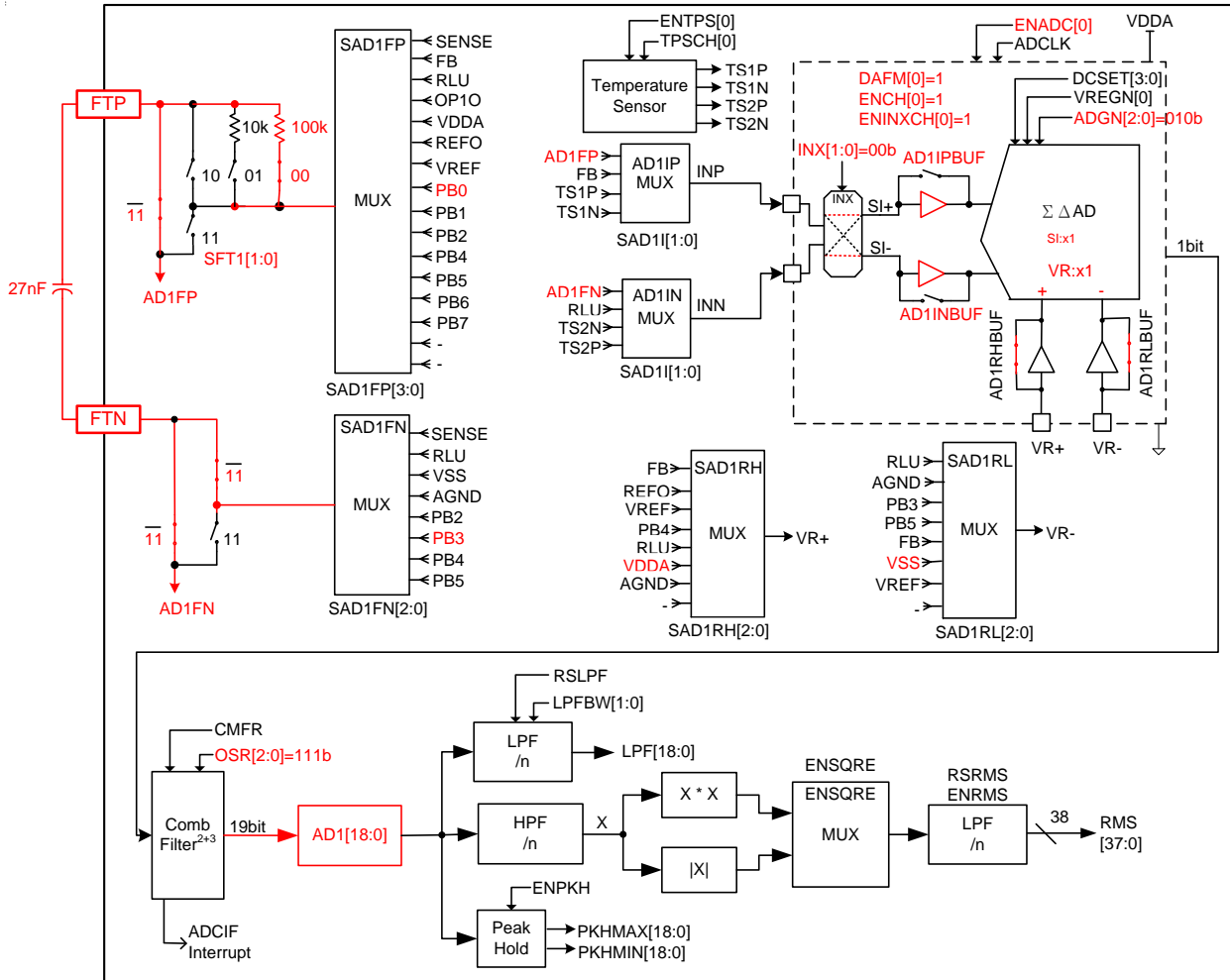

6.3. Diode Function Power Supply Configuration

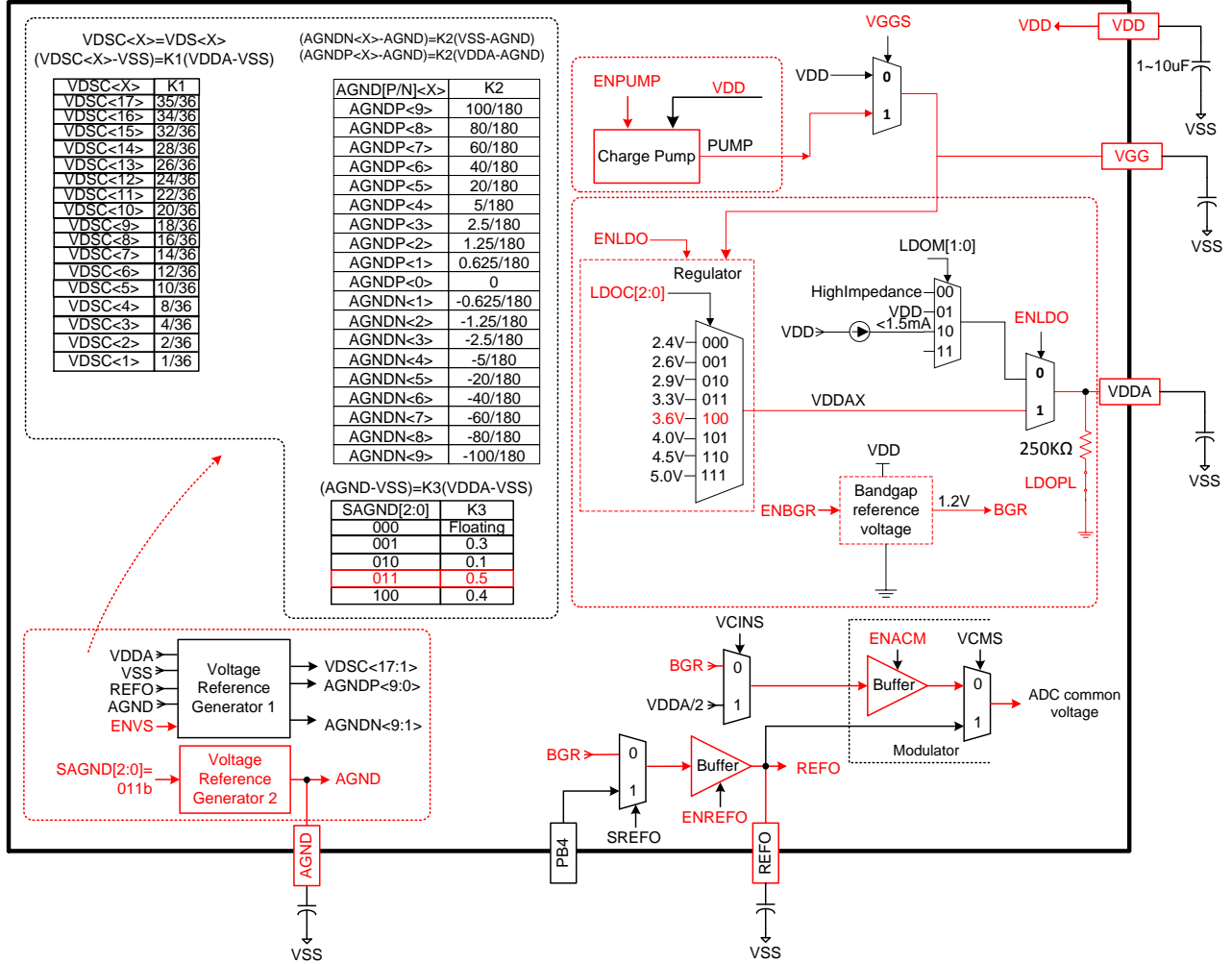

7. Capacitance

There are two ways to measure capacitance, constant voltage and constant current output mode. Under low capacitance (<1μF), users need to use constant voltage output mode for testing whereas using constant current output mode to test high capacitance (>1μF). Capacitance measurement uses charge/discharge test cycle to gain the value.

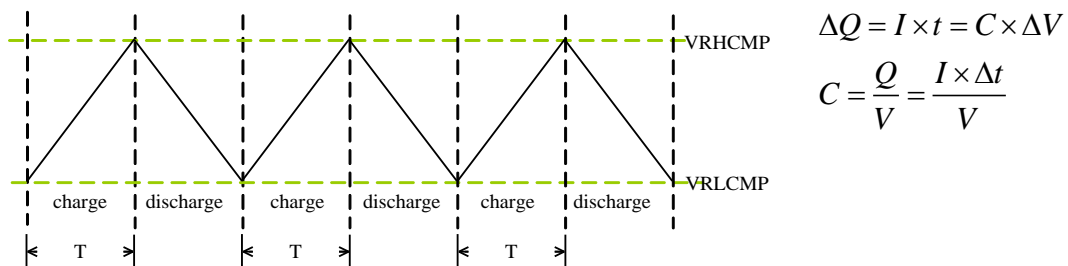

Capacitance measurement test procedure :

1. Select constant voltage (SMODE[5:0]=011010b) and constant current (SMODE[5:0]=0011110b) test mode output.
2. Configure capacitor charge/discharge comparison voltage (VRHCMP、VRLCMP) and the actual charge/discharge of capacitor is decided by comparator, ACPO.
3. Configure CTA[23:8] initial value of Frequency Counter. When INTF0 register, CTF bit is 1, CTC[23:0] divided by CTB[23:0] to gain the cycle length.

If the VREF used for the output is AGNP or AGNDN, the comparison point used by the window comparator should also be AGNDP or AGNDN; on the contrary, if the VREF used is VDSC, the comparison point used by the window comparator should be VDSC.

7.1. 60-600nF (Constant Voltage Charge/Discharge Measurement) Network Configuration

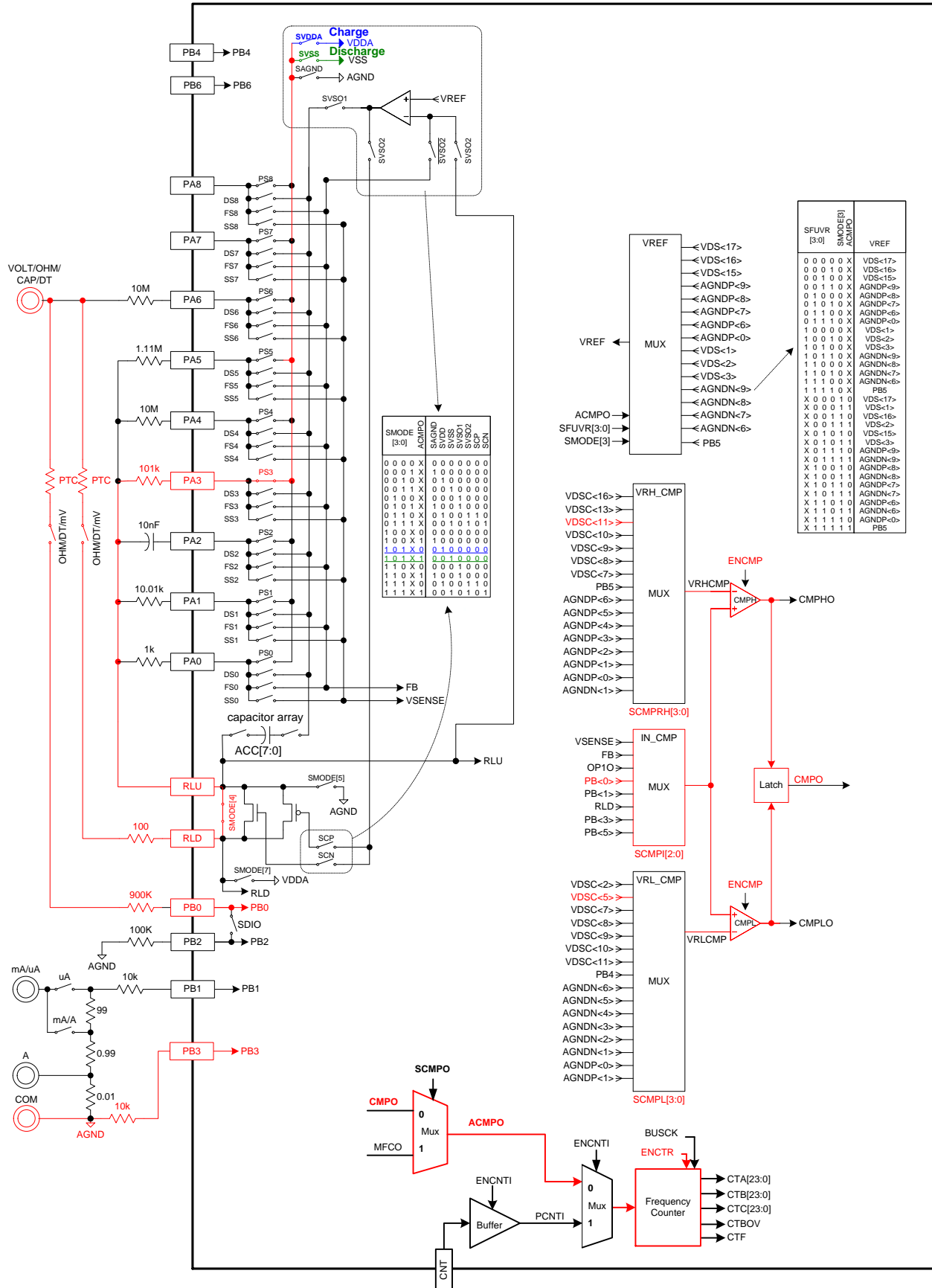

7.2. 6 μ F-60 μ F(Constant Current Charge/Discharge Measurement) Network Configuration

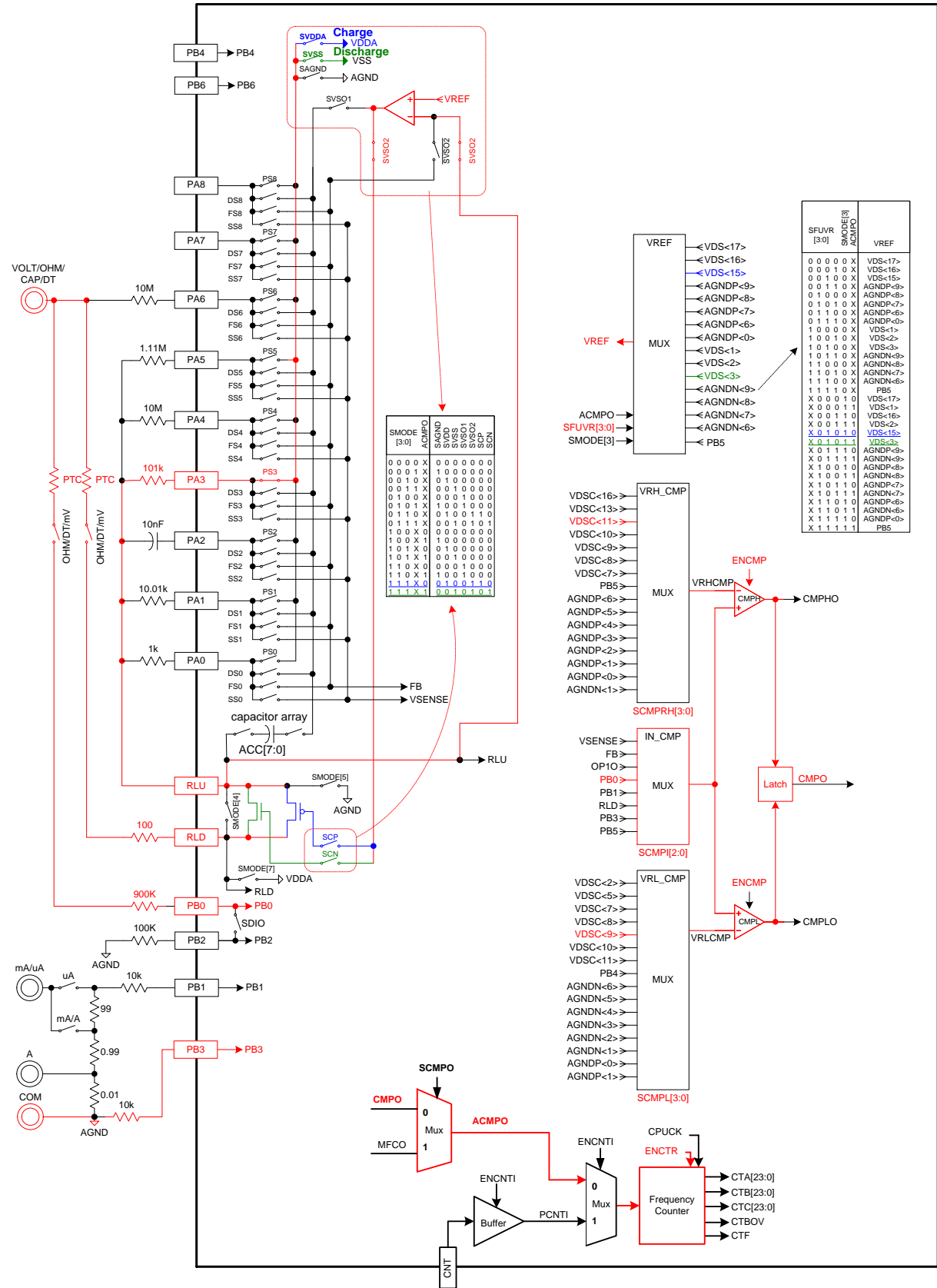

7.3. 600uF~60mF Capacitor Charging Input Network Setting

600uF~60mF capacitors require longer charge/discharge time, the only change of different ranges is the output current. Users can take the voltage difference under a fixed time (t) to gain capacitor value. The change of capacitor value and voltage value is an inverse ratio.

$$C = \frac{Q}{V} = I \times \frac{\Delta t}{\Delta V}$$

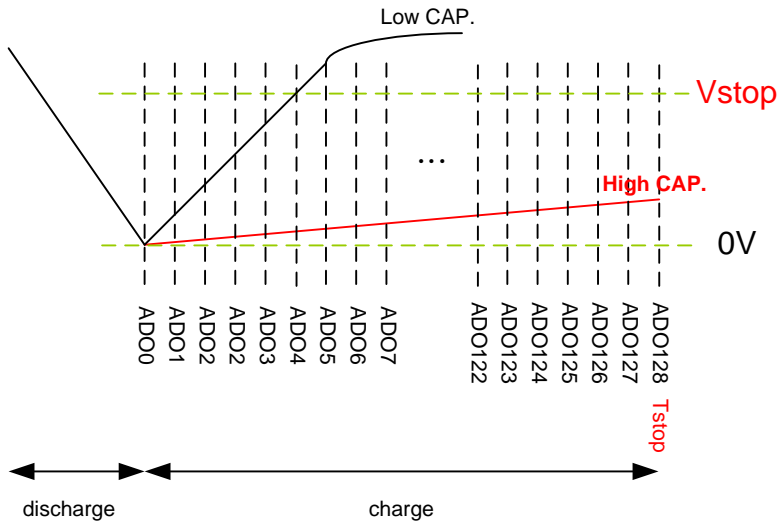

7.3.1. 600uF(Charge) Input Network Configuration

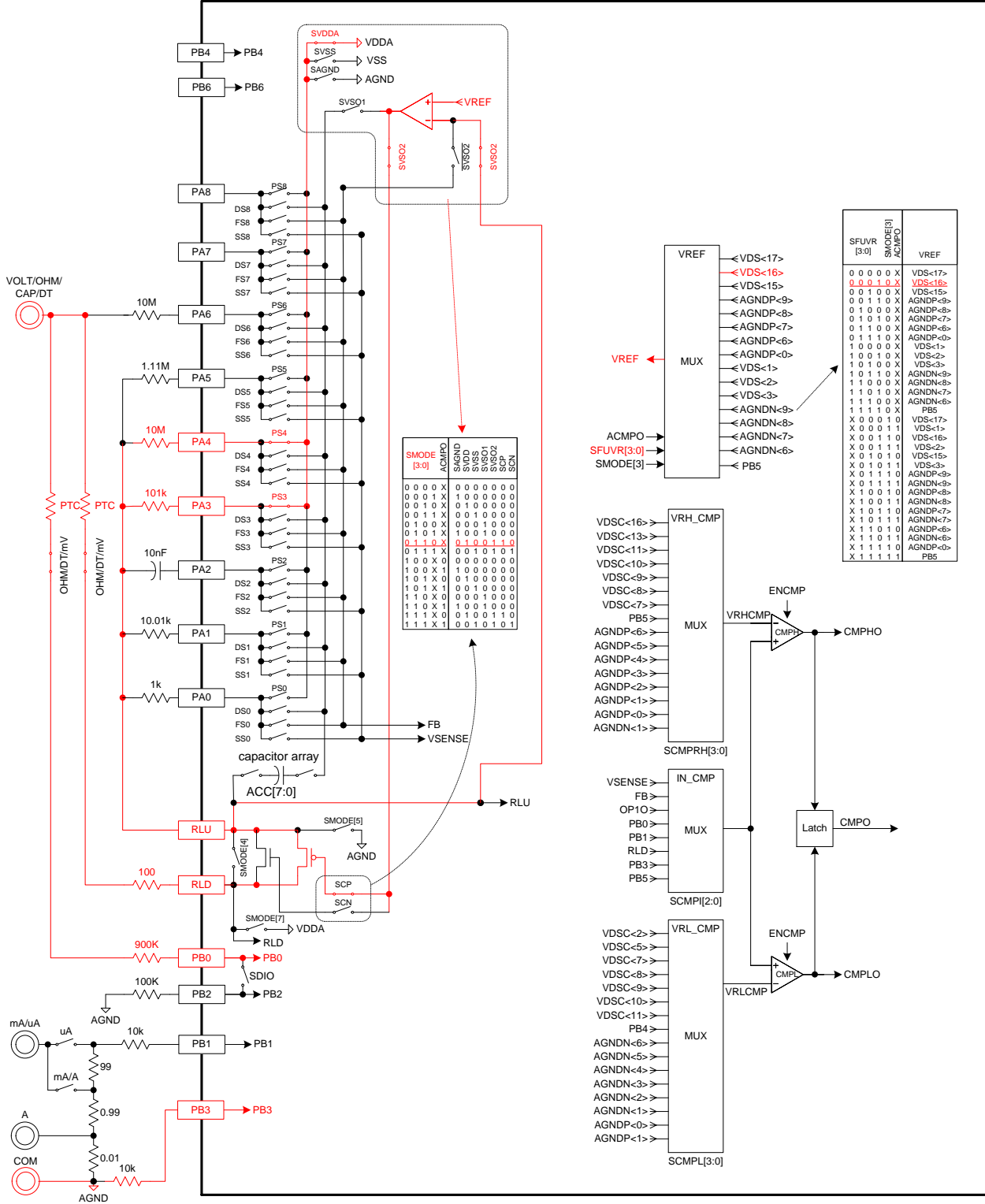

7.3.2. 6mF-60mF(Charge) Input Network Configuration

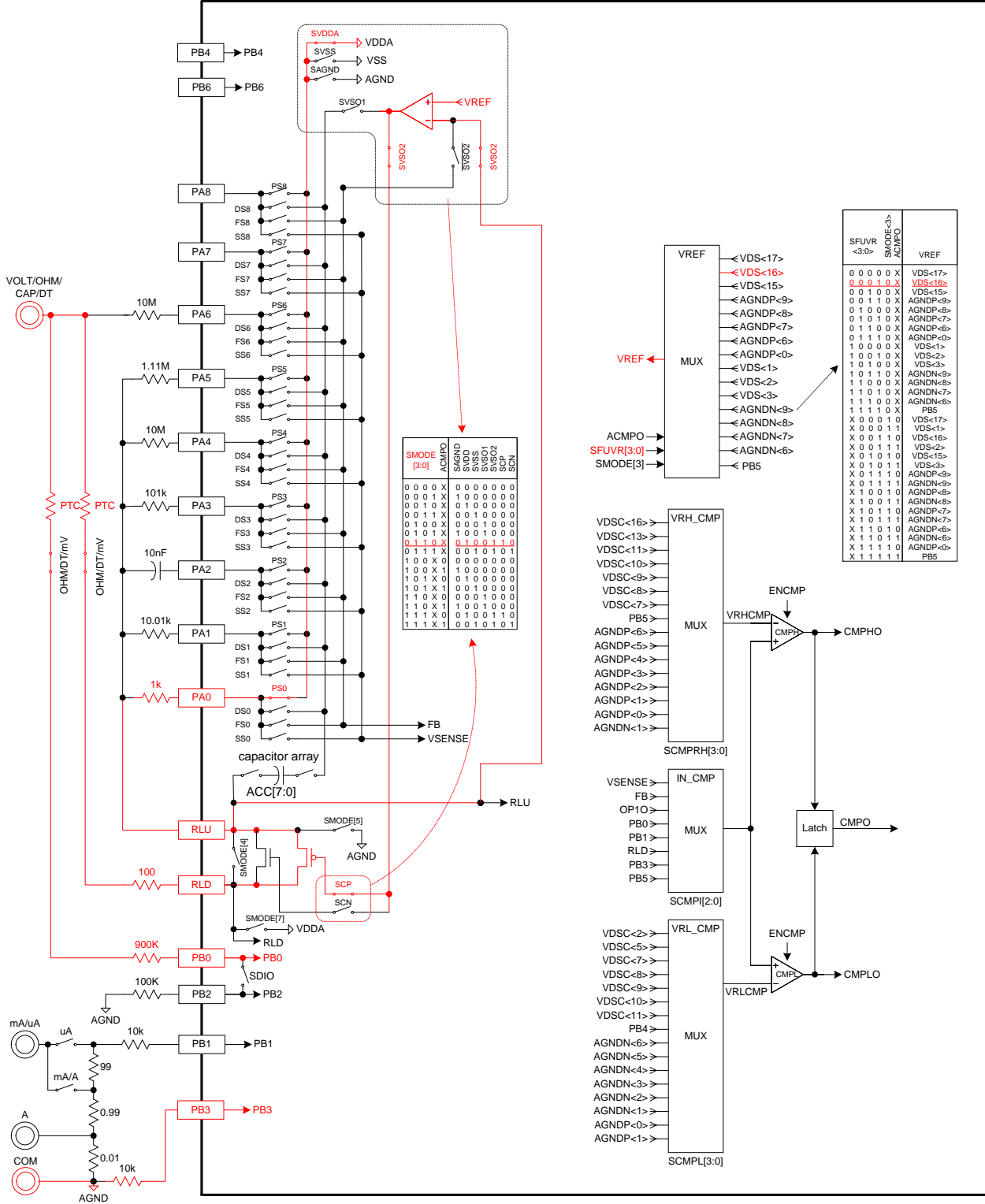

7.4. 600μF~60mF Measurement Network Configuration

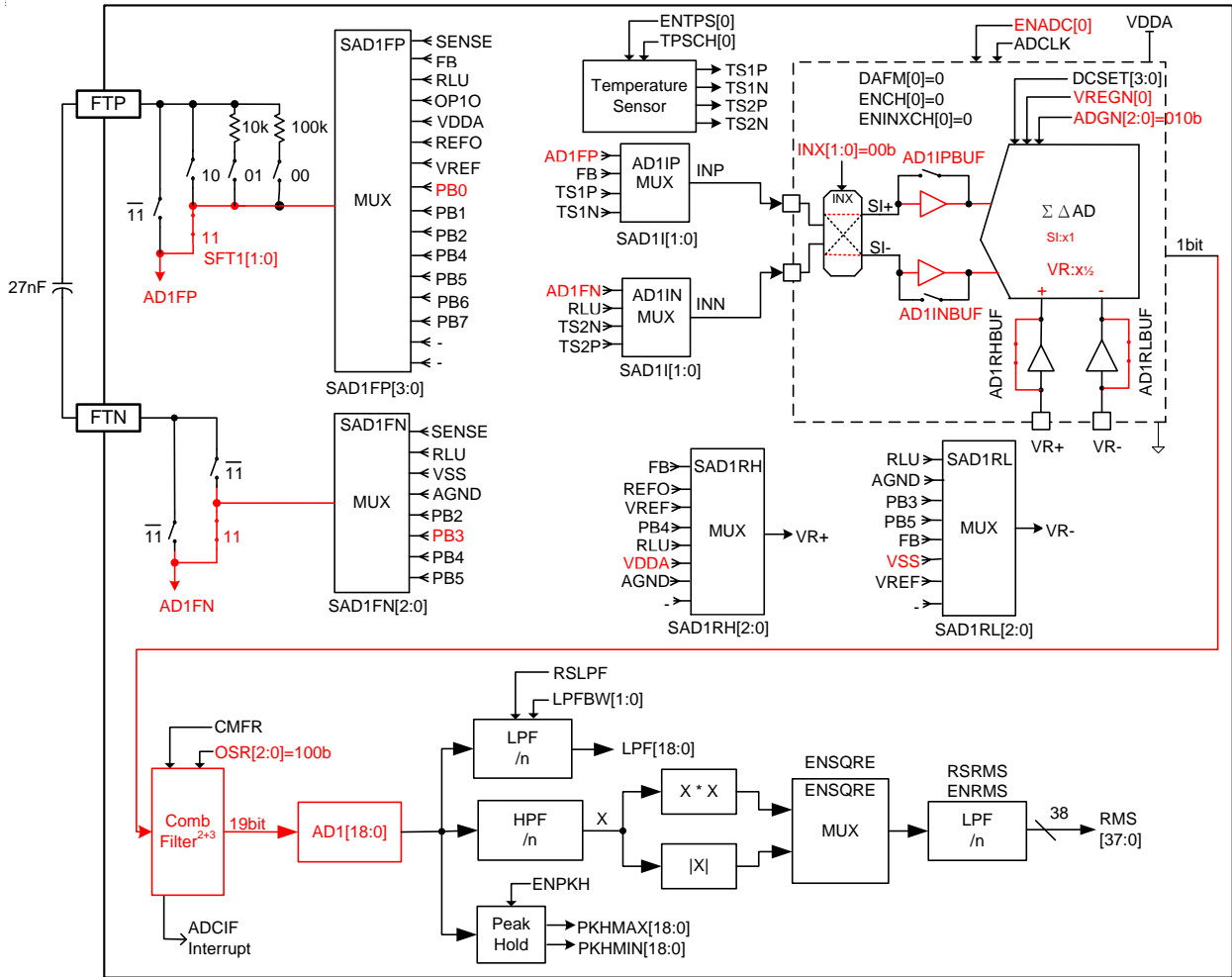

7.5. Discharge(600 μ F~60mF) Input Network Configuration

When discharging, set SMODE[3:0] to 1110b, and set the comparator close to AGND, so that the capacitor discharges itself close to 0V. Regardless of the capacitance, the charging and discharging time is fixed.

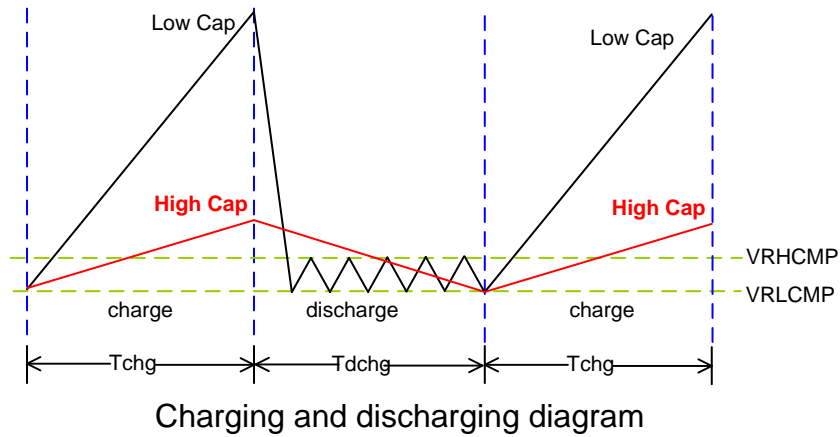

7.6. Capacitance Function Power Supply Configuration

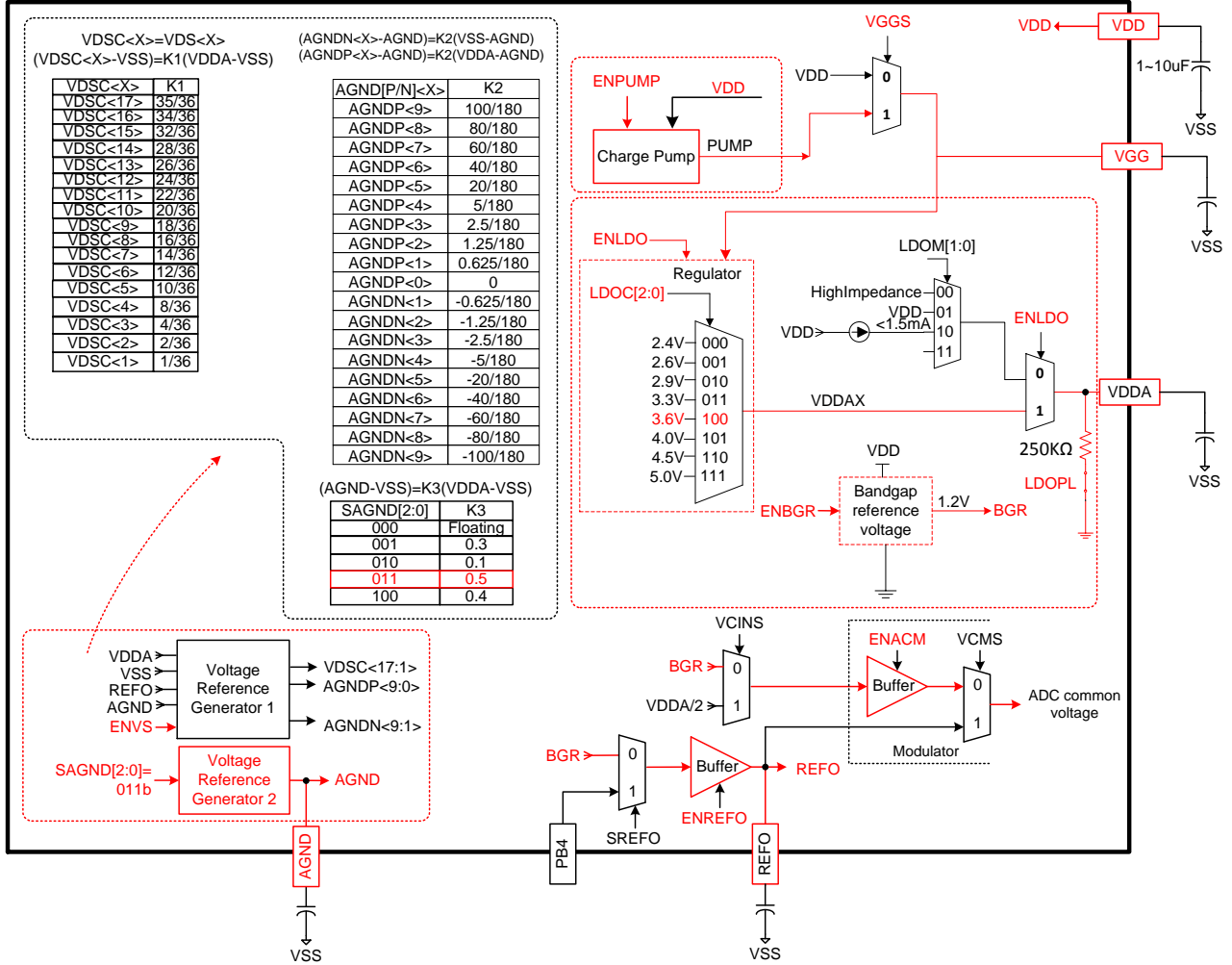

8. Frequency

Frequency measurement can be divided into analog input and digital input. Analog input means that the voltage from PBx or PAX enters OPAMP with voltage follower or amplified 10 times, the signal is isolated from DC by capacitor, and then enter window comparator from PB5, and comparator output (CMPO) input to Frequency Counter; digital input refers to entering from CNT to Frequency Counter.

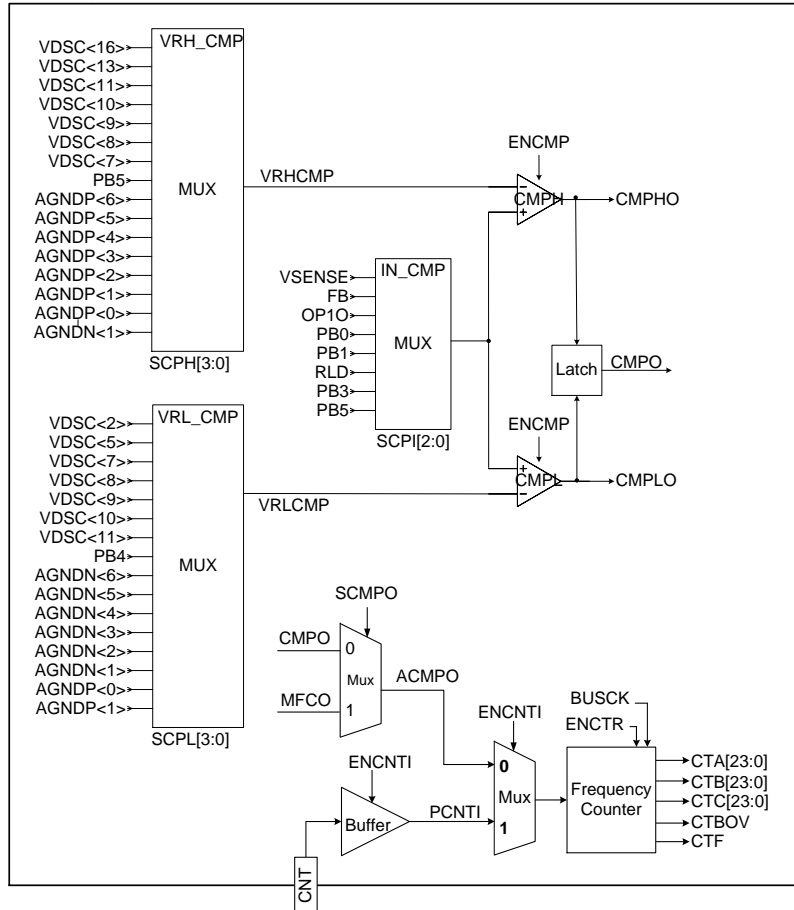

Analog input refers to the signal measurement suitable for positive and negative half cycles. The positive trigger point of the window comparator is VRHCMP; the negative trigger point is VRLCMP. When the analog input signal reaches the positive trigger point of the window comparator, COMP is High; when the signal reaches the negative trigger point of the window comparator, COMP is Low.

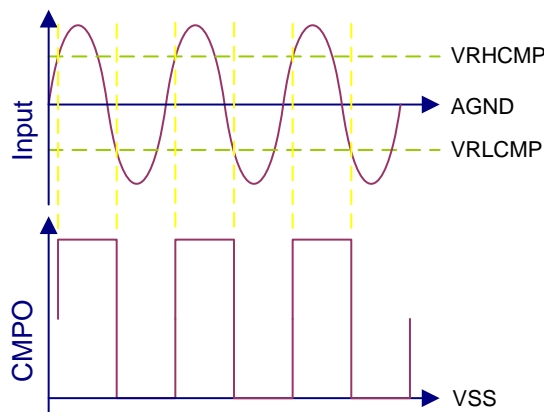

8.1. Example Of Frequency Counter Calculation

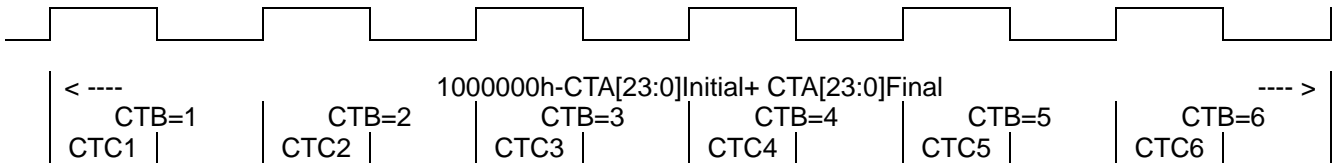

Calculation description (1kHz / 50% as an example)

FSYSCLK: system oscillator frequency is assumed to 4MHz

CTA[23:0]Initial: The default value before CTA counting, the CTA[23:8] program defaults to C000h, and CTA[7:0] is cleared to 00h

CTA[23:0]Final: The value after the CTA count is completed, CTA[23:0]Initial is C00000h, in the case of 1kHz, it is 000760h

CTB[23:0]: the number of cycles within the time, CTA[23:0]Initial is C00000h, in the case of 1kHz, it is 000419h

CTC[23:0]: the count of the total time of High, CTA[23:0]Initial is C00000h, when Duty 50% is 20043Ah

Count time:

$$T = [1000000h-CTA[23:0]Initial+ CTA[23:0]Final]/FSYSCLK$$

$$=(1000000h-C00000h +000760h)/3D0900h \text{ --- } >\text{hexadecimal}$$

$$=(16777216-12582912+1888)/4000000=1.0490 \text{ --- } >\text{decimal}$$

Standby signals frequency:

$$\text{Freq} = \text{CTB}[23:0]/T$$

$$= 1049/1.0490=1000 \text{ Hz}$$

Standby signal, Duty Cycle:

$$\text{Duty Cycle} = \text{CTC}[23:0]/\{1000000h-CTA[23:0]Initial + CTA[23:0]Final\}$$

$$= 20043Ah/400760h \text{ --- } >\text{hexadecimal}$$

$$= 2098234/4196192=0.5=50\% \text{ --- } >\text{decimal}$$

8.2. Analog Input 8.2.1. Voltage Input

The method of voltage and frequency measurement is to divide the voltage from PAn into OPAMP from internal SENSE. Please refer to "Voltage" chapter for input network settings.

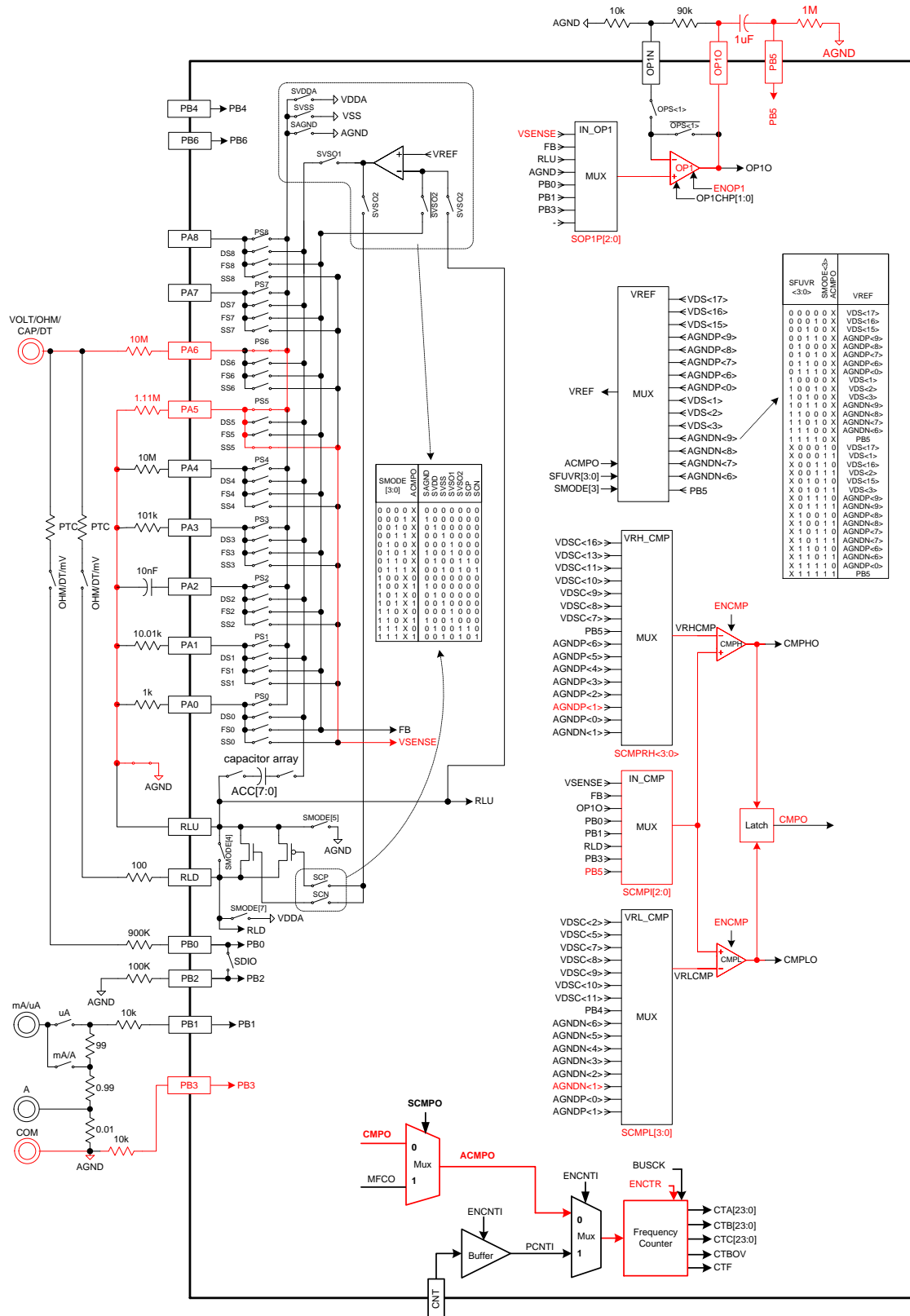

8.2.2. MilliVolt / Current Input

Low voltage or current and measuring frequency method is to enter OPAMP from PB0 or PB1. Please refer to "Millivolts" or "Current" chapter for input network settings.

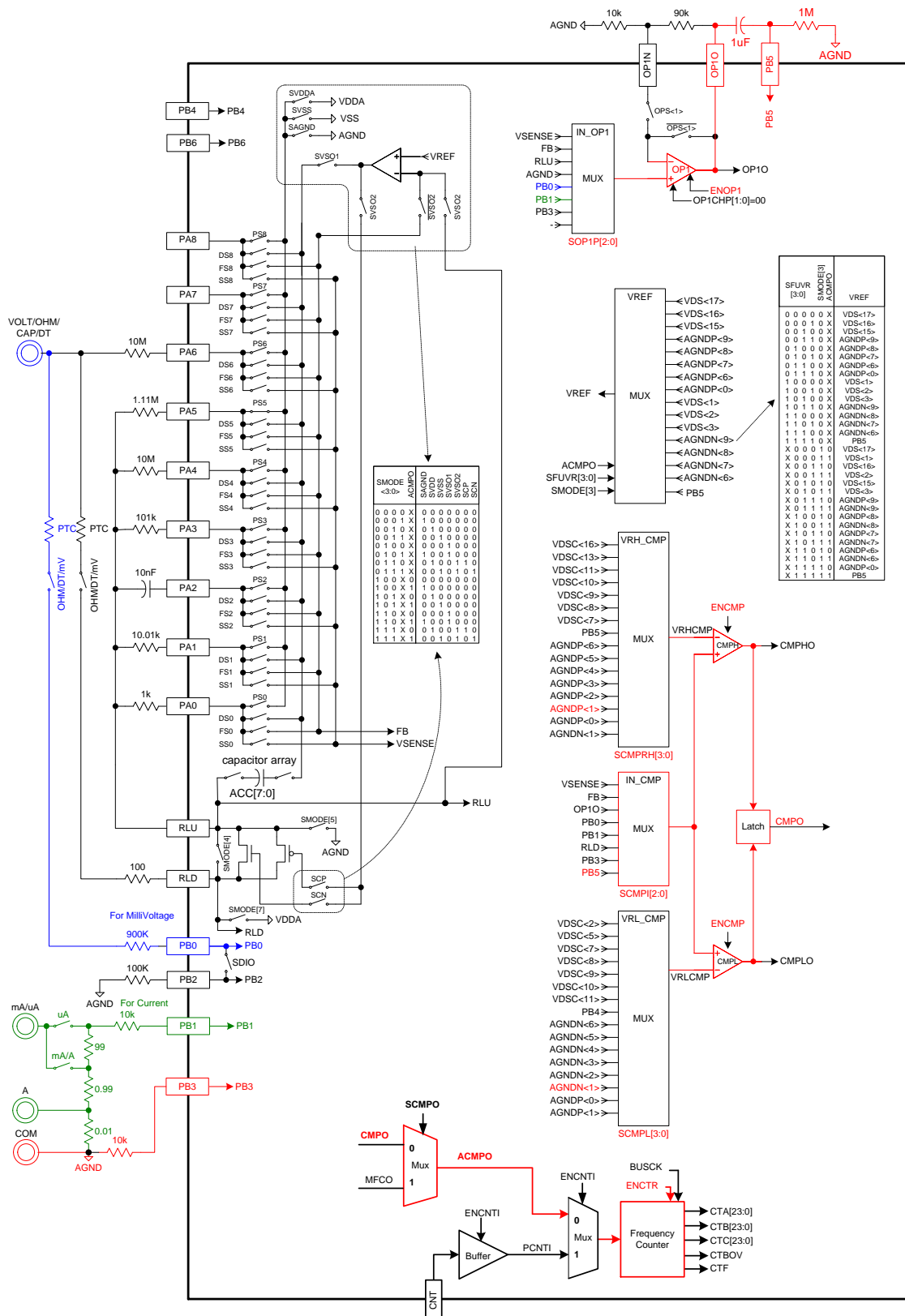

8.3. Digital Input
8.3.1. CNT Input

CNT (PT3.6) is a digital pin. When there is no signal input, the pin must be half the voltage of the digital power supply.

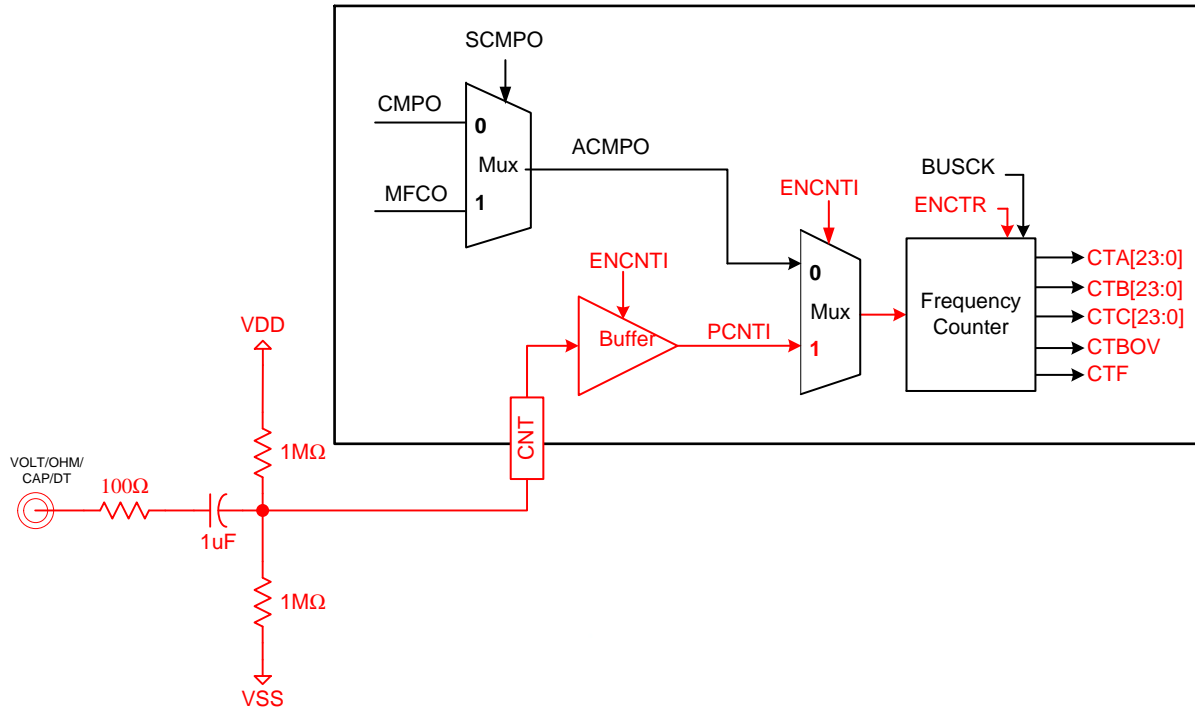

8.4. Frequency Function Power Supply Configuration

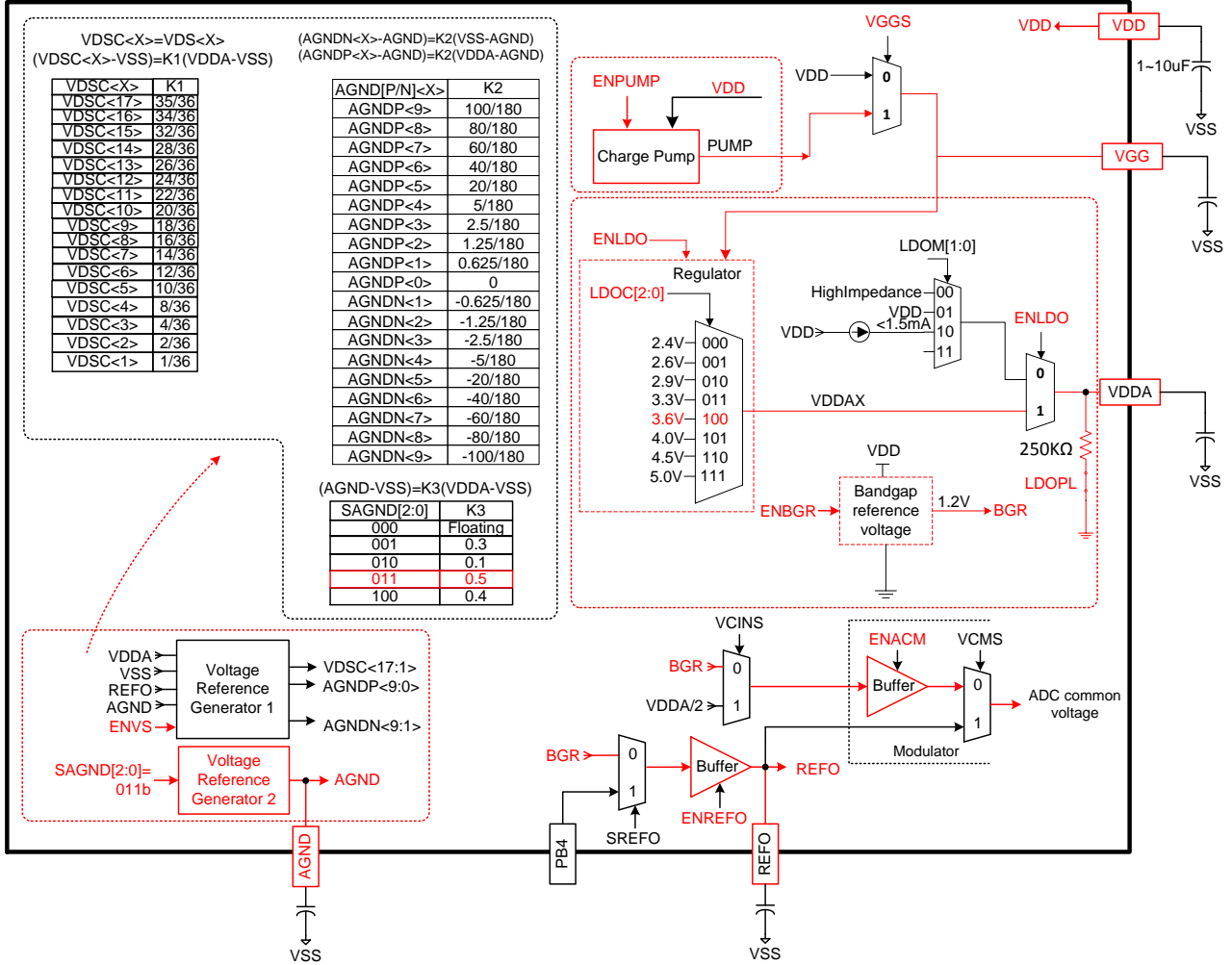

9. Application Q&A

9.1. Why is there an error in the voltage function ADC negative terminal selection PBx?

Answer:

In many functional applications, PBx is used as AGND Sense, but in high voltage range, the internal SMODE[5] switch impedance is large, which will cause measurement errors. If the external RLU is not grounded, the Voltage function recommends that the ADC input select Sense-RLU.

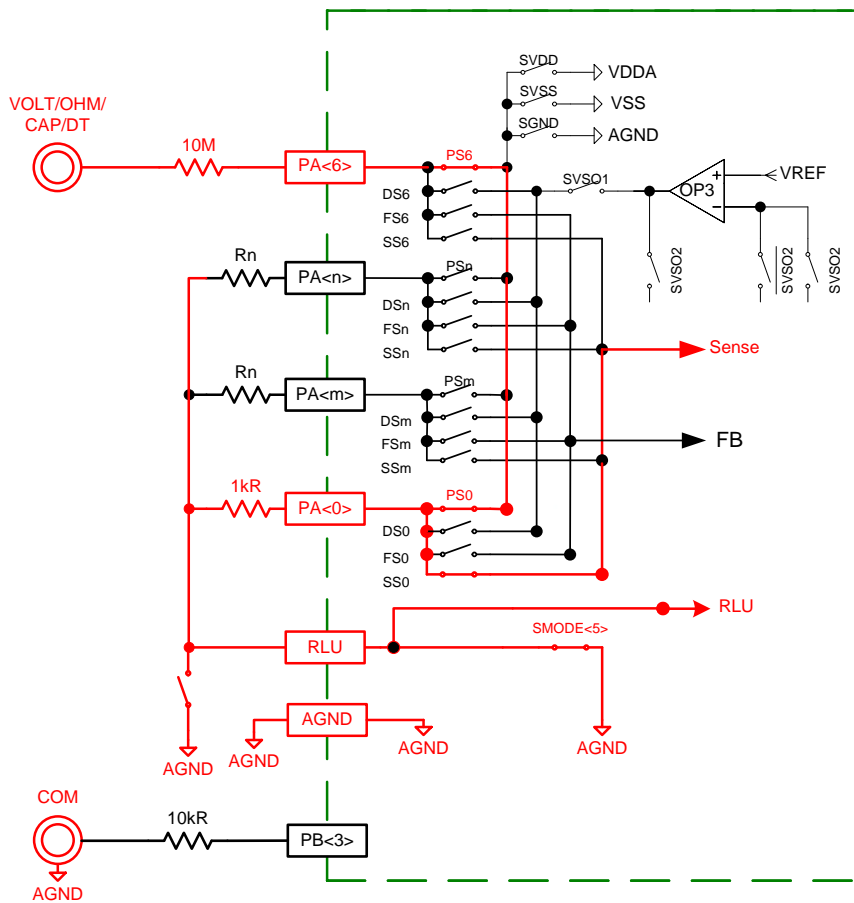

9.2. Continuity and 60MΩ response speed is too slow

Answer:

The reaction speed is too slow because the measurement circuit has a 27nF capacitor. When the meter input is not short-circuited, the 27nF capacitor is charged, and the discharge speed is too slow when the meter is short-circuited or when measuring large resistances.

If the Pre-Filter inside the chip is ignored during Continuity and 60MΩ measurement, the response speed can be accelerated, but the displayed value will be unstable.

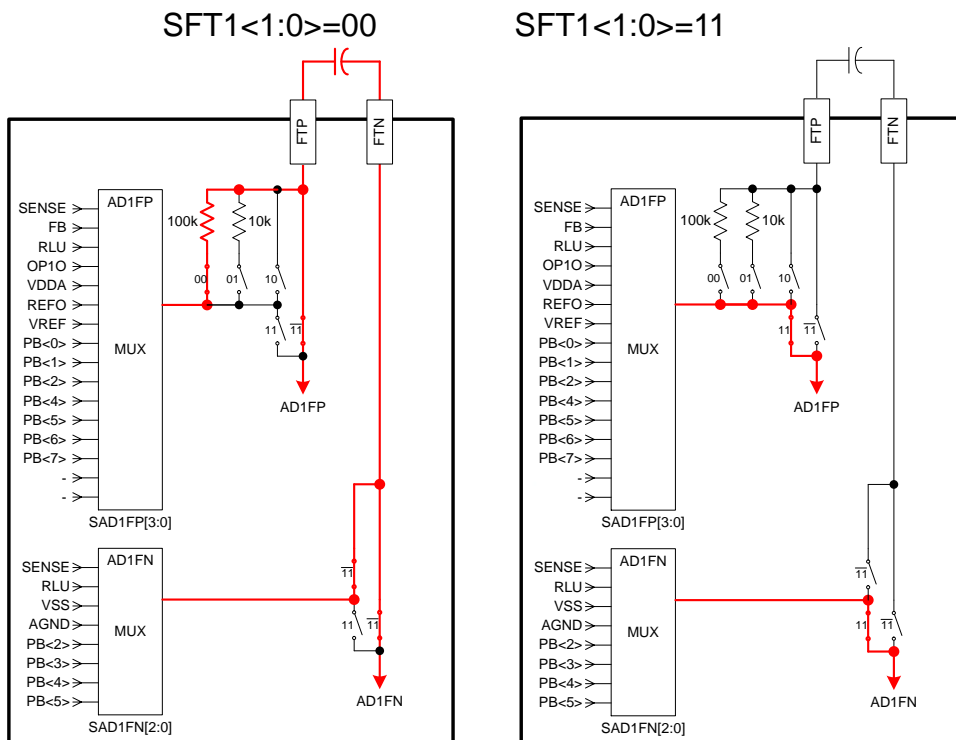

10. Revision History

Major differences are stated thereafter:

Version	Page	Date	Summary
V02	All	2021/02/25	First edition