



HY16F3910 Series IDE Hardware User's Manual

Table of Contents

1. PACKAGE CONTENTS	4
2. SAFETY PRECAUTIONS	5
3. SOFTWARE INSTALLATION REQUIREMENTS	6
3.1. IDE Software Installation Requirements	6
4. DESCRIPTION OF THE HARDWARE TOOL	7
4.1. Architecture description	7
4.2. HY16F Mini Link Debug Tool Introduction.....	7
4.3. Introduction to Target Board.....	9
4.4. Target Board Circuit Diagram.....	12
4.5. LCD Board Introduction	13
4.6. HY16F Mini Link Debug Tool and Target Board Hardware Connection Steps	16
5. HARDWARE CONNECTION INTRODUCTION	17
6. REVISIONS	18

Attention:

- 1、 HYCON Technology Corp. reserves the right to change the content of this datasheet without further notice. For most up-to-date information, please constantly visit our website: <http://www.hycontek.com> .
- 2、 HYCON Technology Corp. is not responsible for problems caused by figures or application circuits narrated herein whose related industrial properties belong to third parties.
- 3、 Specifications of any HYCON Technology Corp. products detailed or contained herein stipulate the performance, characteristics, and functions of the specified products in the independent state. We does not guarantee of the performance, characteristics, and functions of the specified products as placed in the customer's products or equipment. Constant and sufficient verification and evaluation is highly advised.
- 4、 Please note the operating conditions of input voltage, output voltage and load current and ensure the IC internal power consumption does not exceed that of package tolerance. HYCON Technology Corp. assumes no responsibility for equipment failures that resulted from using products at values that exceed, even momentarily, rated values listed in products specifications of HYCON products specified herein.
- 5、 Notwithstanding this product has built-in ESD protection circuit, please do not exert excessive static electricity to protection circuit.
- 6、 Products specified or contained herein cannot be employed in applications which require extremely high levels of reliability, such as device or equipment affecting the human body, health/medical equipments, security systems, or any apparatus installed in aircrafts and other vehicles.
- 7、 Despite the fact that HYCON Technology Corp. endeavors to enhance product quality as well as reliability in every possible way, failure or malfunction of semiconductor products may happen. Hence, users are strongly recommended to comply with safety design including redundancy and fire-precaution equipments to prevent any accidents and fires that may follow.
- 8、 Use of the information described herein for other purposes and/or reproduction or copying without the permission of HYCON Technology Corp. is strictly prohibited.

HY16F3910 IDE Hardware User's Manual

1. Package Contents

HY16F3910-DK01 Hardware development kit includes HY16F3910-N088 Target Board and HY16F Mini Link Debug Tool(refer to table 1-1).

Integrated Hardware development kit helps to develop MCU application program of HY16F3910 Series. Program compiling, hardware debug, IC programming was implemented through NB/PC end connection. This user's manual mainly introduces the IDE hardware development tool, the related hardware is equipped as shown below:

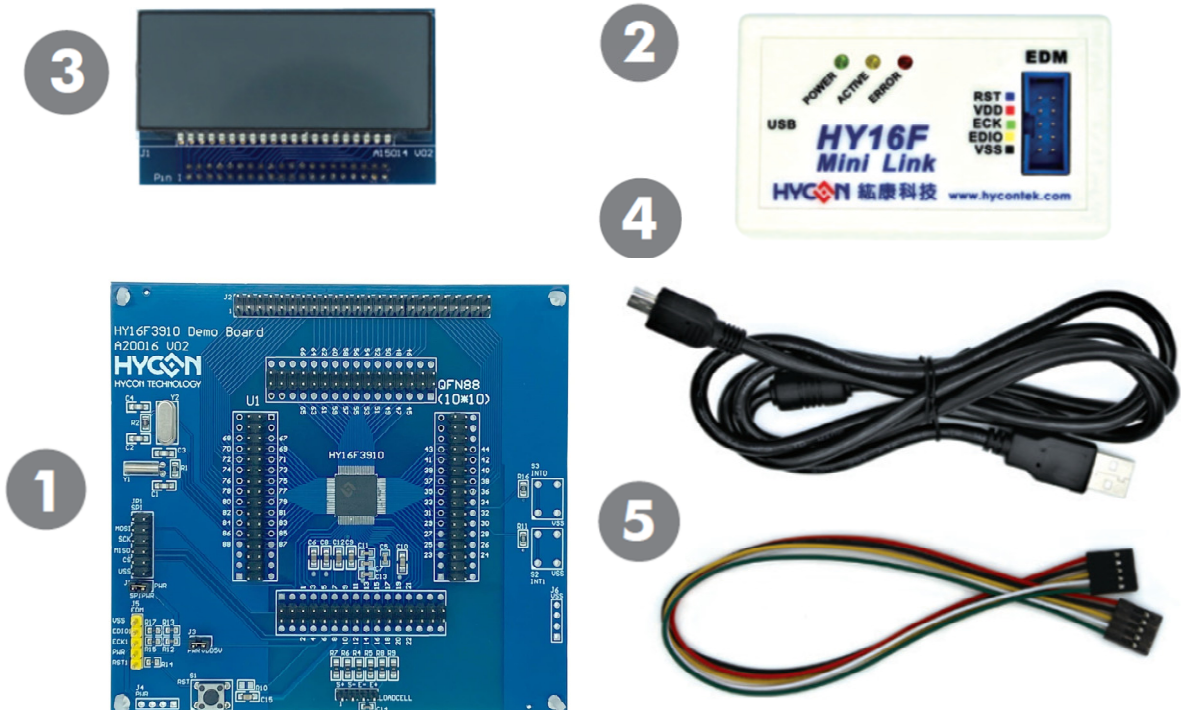

Model No.	Part Name	Description	Quantity
HY16F3910-DK01	1.HY16F3910-IM01	HY16F3910-N088 Target Board	1
	2.HY16000-CM04	HY16F Mini Link Debug Tool	1
	3.HY10000-AM01	LCD Board (3.0V, 4COM x 17SEG)	1
	4.Cable line	USB Type A to Mini B cable	1
	5.EDM line	5pin to 5 pin (2.54mm pitch)	1

Table 1-1

2. Safety Precautions

- Do not place heavy objects on the display panel, in order to avoid damage caused by stress.
- Place the application display boards at steady place, so as to avoid falling damage.
- Do not use this product with the input voltage which is not meeting the electrical specifications, , in order to avoid working abnormally or damage
- Avoid application display boards being touched by liquid, dirt and avoid being exposed to moisture during operation. This application should be kept in a dry environment, so as not to affect the function and performance
- Remove the power supply when not using it.
- When following status occurred, please remove the power supply immediately, and contact our engineer.
 - Power Supply line is worn or damaged.
 - Power source (battery) connected but no any light on while operating.
 - Component off.

3. Software Installation Requirements

3.1. IDE Software Installation Requirements

Minimum System Requirements of operating AndeSight RDS IDE:

- (1) PC/NB hardware requirement:
 - IBM PC compatible X86 system CPU
 - 4GB DDR Memory
 - 8GB HD Hard Disk Drive Capacity
- (2) Supported Products:
 - HY16F3910 Series
- (3) Supported Hardware Model No.:
 - HY16F3910-DK01: HY16F3910 hardware development kit.
- (4) Supported software version:
 - AndeSightV3.2.1RDS above
 - HYCON 32-bit MCU Device V0.34 above
- (5) Supported Operating system:
 - Windows XP (32-Bit System), Windows 7(32/64-Bit System), Windows 8(32/64-Bit System), Windows 10(32/64-Bit System).
- (6) Apply the following interface modes:
 - USB Port with libusb-win32 device
 - HY16F Mini Link Debug Tool 's USB Port driver uses the Windows general USB device driver.(Figure 3-1)

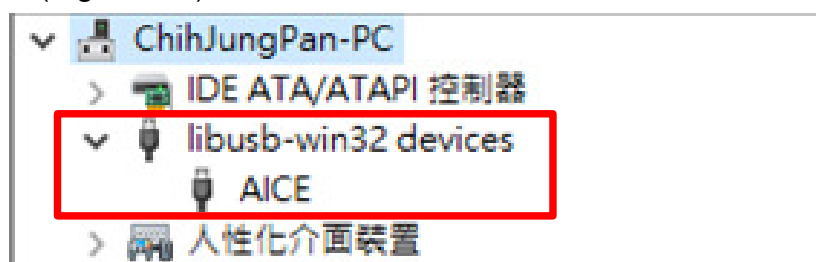

Figure 3-1

4. Description of the hardware tool

4.1. Architecture description

HY16F Mini Link Debug Tool(ICE) is a control device between the HY163910-N088 Target Board and AndeSight RDS IDE software.

Program compiling, software debug, hardware debug, IC programming was implemented through NB/PC end connection.

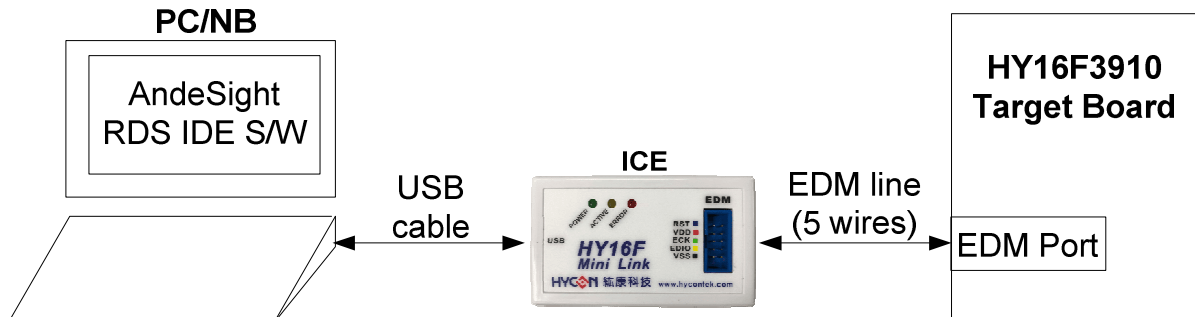

Figure 4-1

Note: EDM is Embedded Debug Module

4.2. HY16F Mini Link Debug Tool Introduction

HY16F Mini Link Debug Tool (model:HY16000-CM04) is universal for HY16F series products (as shown in Figure 4-2), the following is the introduction of the HY16F Mini Link Debug Tool:

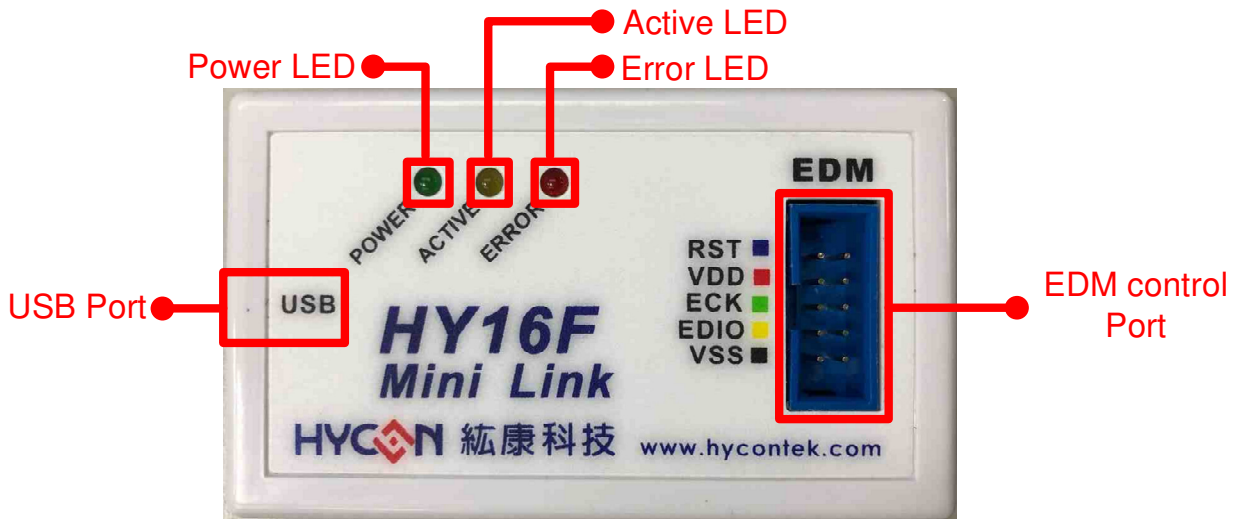

Figure 4-2

(1) Power LED

Function: Power LED (Green LED)

Description: When the USB Port is connected to a computer or an external 5V power supply, the light indicates that the Control Box is powered.

HY16F3910

IDE Hardware User's Manual

(2) Active LED

Function: Active LED (Yellow LED)

Description: When entering Debug mode, the Active LED keeps flashing.

(3) Error LED

Function: Error LED (Red LED)

Description: When the USB Port is connected to a computer or an external 5V power supply, but the EDM control port is not connected to Target Board, the Error LED will light on.

(4) USB Port

Function: USB Port

Description: Mini B Cable connector

(5) EDM control Port

Function: EDM control communication interface port , used to connect with the EDM interface of the Target Board to control the chip.

Description: The function is defined as follows

Name	Description
RST	RST Pin, connected to the RST pin of the HY16F3910.
VDD	VDD Pin, connected to the VDD5V pin of the HY16F3910. Note: HY16F Mini Link Debug Tool fixed output 3.3V with 200mA power supply.
ECK	EDM Clock Pin, connected to the ECK pin of the HY16F3910.
EDIO	EDM Data Input / Output Pin, connected to the EDIO pin of the HY16F3910.
VSS	Ground Pin, connected to the VSS pin of the HY16F3910.

4.3. Introduction to Target Board

The Target Board (model: HY16F3910-IM01) is commonly used for HY16F3910 series products (Figure 4-3) and demonstrate the function of HY16F3910.

The following describes the appearance and functions of the Target board:

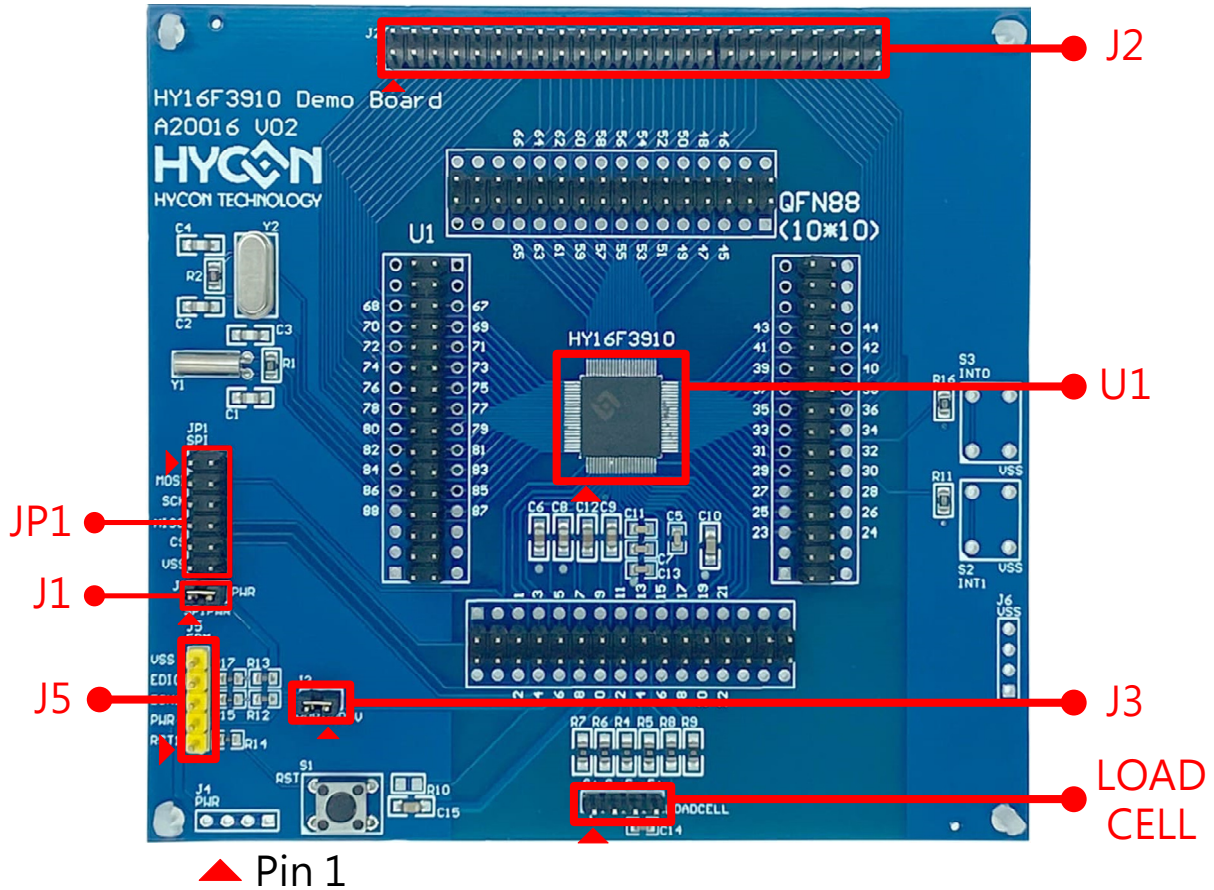

Figure 4-3

- (1) U1
Function: Target Board Chip, called HY16F3910 (Part No: HY16F3910-N088).

- (2) J1
Function: SPI/PWR Power Source Selection.

When J1's pin1-2 are shorted together, the SPI/PWR Powered by PWR.

Description: Pin are defined as follows

Name	Pin	Name
SPI/PWR	1 2	PWR

(3) J2

Function: Target Board Chip's LCD port.

Description: Pin are defined as follows

Name	Pin		Name
COM0	1	2	COM1
COM2	3	4	COM3
SEG0	5	6	SEG1
SEG2	7	8	SEG3
SEG4	9	10	SEG5
SEG6	11	12	SEG7
SEG8	13	14	SEG9
SEG10	15	16	SEG11
SEG12	17	18	SEG13
SEG14	19	20	SEG15
SEG16	21	22	SEG17
SEG18	23	24	SEG19
SEG20	25	26	SEG21
SEG22	27	28	SEG23
SEG24	29	30	SEG25
SEG26	31	32	SEG27
SEG28	33	34	SEG29
SEG30	35	36	SEG31
SEG32	37	38	SEG33
SEG34	39	40	SEG35
SEG36	41	42	SEG37
SEG38	43	44	SEG39
SEG40	45	46	SEG41
SEG42	47	48	SEG43

(4) J3

Function: Target Board Chip's Current measurement.

It can be used to measure chip current by ammeter.

Description: Pin are defined as follows

Name	Pin		Name
VDD5V	1	2	PWR

Note: When J3 pin is not used to measurement, keep the J3 pin shorted together.

(5) J5

Function: Target Board Chip's EDM Port and connected to the HY16F Mini Link Debug Tool for Debug.

Description: Pin are defined as follows

Pin	Name	Description
1	RST1	RST Pin, connected to the RST pin of the HY16F Mini Link Debug Tool.
2	PWR	PWR Pin, connected to the VDD pin of the HY16F Mini Link Debug Tool.
3	ECK1	ECK1 Pin, connected to the ECK pin of the HY16F Mini Link Debug Tool.
4	EDIO1	EDIO1 Pin, connected to the EDIO pin of the HY16F Mini Link Debug Tool.
5	VSS	VSS Pin, connected to the VSS pin of the HY16F Mini Link Debug Tool.

(6) JP1

Function: Target Board Chip's SPI Port.

When J1's pin1-2 are shorted together, the SPIPWR Powered by PWR;
If PWR is 3V, then SPIPWR is 3V.

Description: Pin are defined as follows

Name	Pin		Name
SPIPWR	1	2	SPIPWR
MOSI	3	4	MOSI
SCK	5	6	SCK
MISO	7	8	MISO
CS	9	10	CS
VSS	11	12	VSS

(7) LOAD CELL

Function: Target Board Chip's ADC Bridge Sensor Connector and it can measure circuit. The ADC Bridge Sensor is composed of AIO0, AIO1, AIO2 and AIO3.

Description: Pin are defined as follows

Pin	Name
1	S+
2	S-
3	E-
4	E+

HY16F3910 IDE Hardware User's Manual

4.4. Target Board Circuit Diagram

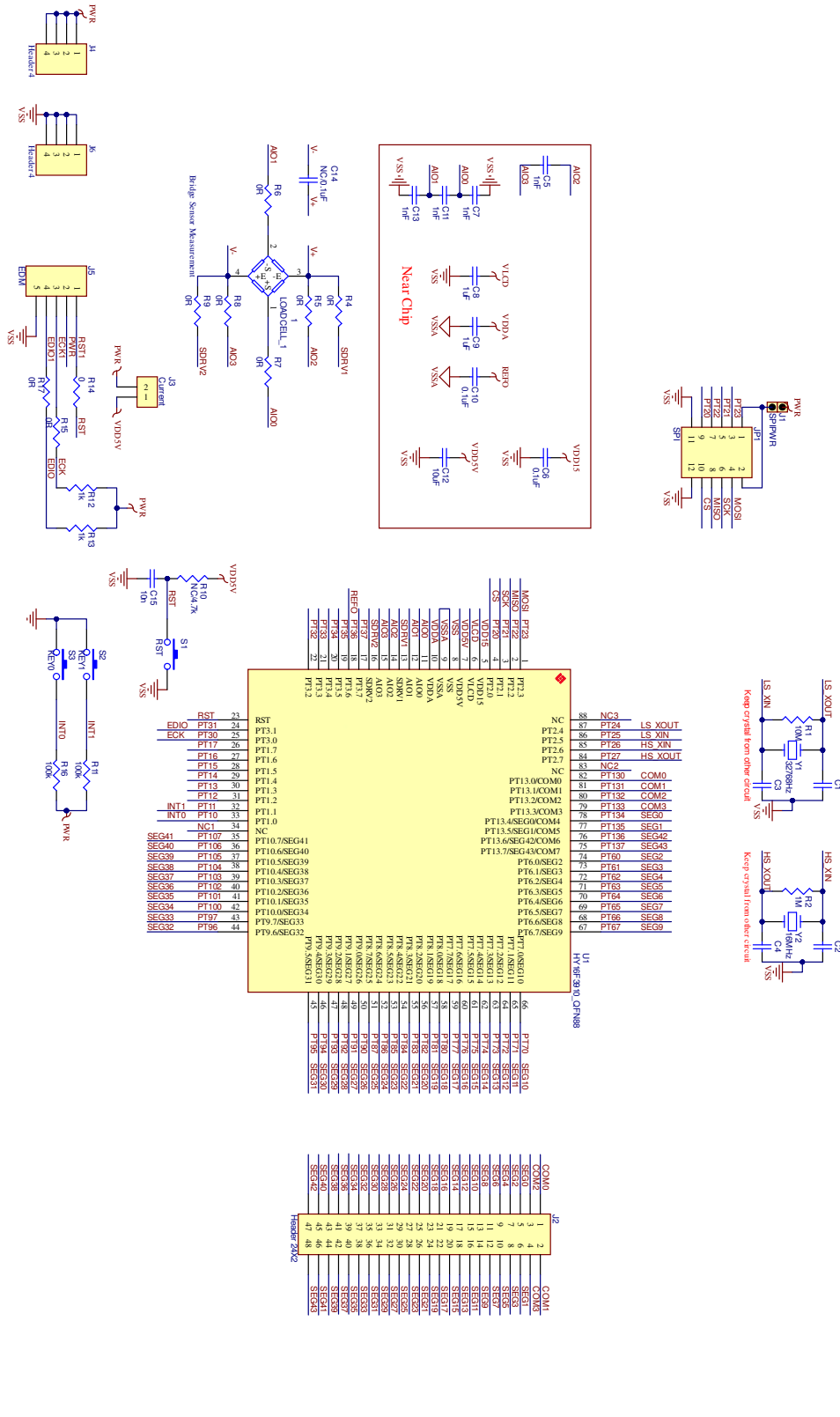

Note:
This Target Board circuit diagram is placed in the Andes IDE software directory installed below: "`\Andestech\AndeSight_RDS_v321\doc\Hycon\ICESchematic\`".

HY16F3910 IDE Hardware User's Manual

4.5. LCD Board Introduction

The LCD panel (**model:HY10000-AM01**) on HY16F3910-N088 Target Board is HYCON self-owned mold, it's symbol and pin diagram is shown in below graph.

It's panel specification is as follows:

- (1) Operating Voltage: 3.0V
- (2) Visible Angle: 60 degree
- (3) Operating Frequency: 60Hz
- (4) Bias:1/3 bias
- (5) Waveform:1/4 duty
- (6) Pin: 90 degree

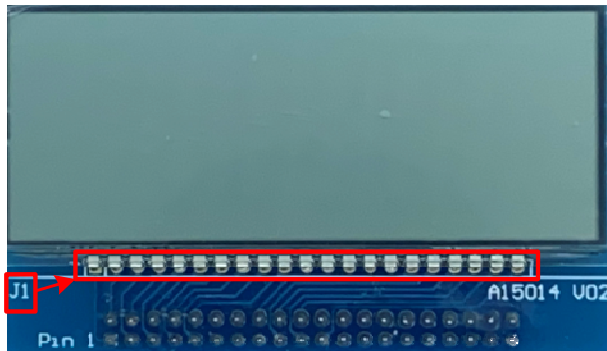

Top side of HY10000-AM01

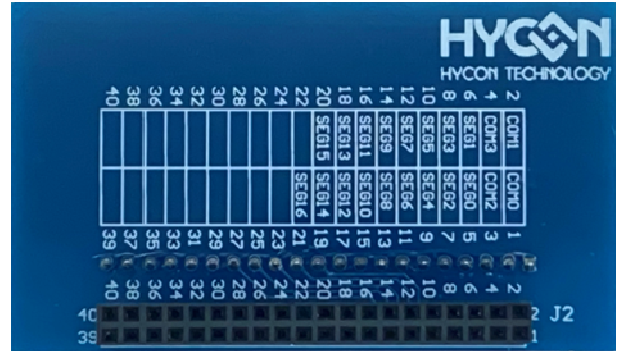

Bottom side of HY10000-AM01

J1 pin assignment

Pin No.	1	2	3	4	5	6	7	8	9	10	11
Pin Name	COM0	COM1	COM2	COM3	SEG0	SEG1	SEG2	SEG3	SEG4	SEG5	SEG6

Pin No.	12	13	14	15	16	17	18	19	20	21
Pin Name	SEG7	SEG8	SEG9	SEG10	SEG11	SEG12	SEG13	SEG14	SEG15	SEG16

J2 pin assignment

Pin Name	COM0	COM2	SEG0	SEG2	SEG4	SEG6	SEG8	SEG10	SEG12	SEG14	SEG16
Pin No.	1	3	5	7	9	11	13	15	17	19	21
Pin No.	2	4	6	8	10	12	14	16	18	20	22
Pin Name	COM1	COM3	SEG1	SEG3	SEG5	SEG7	SEG9	SEG11	SEG13	SEG15	-

HY16F3910

IDE Hardware User's Manual

● HY1000-AM01: LCD Logical Table

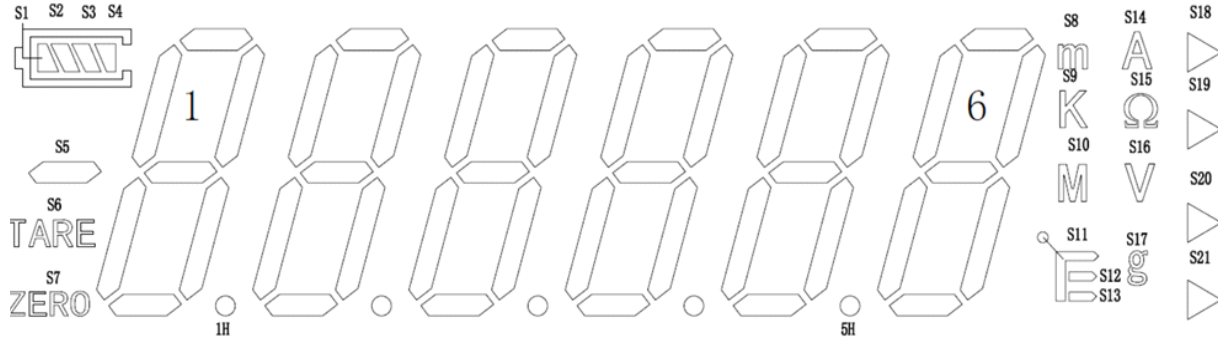

	SEG0	SEG1	SEG2	SEG3	SEG4	SEG5	SEG6	SEG7	SEG8	SEG9	SEG10	SEG11	SEG12	SEG13	SEG14	SEG15	SEG16
COM0	1A	1E	2A	2E	3A	3E	4A	4E	5A	5E	6A	6E	S1	S5	S10	S9	S18
COM1	1B	1F	2B	2F	3B	3F	4B	4F	5B	5F	6B	6F	S2	S6	S11	S14	S19
COM2	1C	1G	2C	2G	3C	3G	4C	4G	5C	5G	6C	6G	S3	S7	S12	S15	S20
COM3	1D	1H	2D	2H	3D	3H	4D	4H	5D	5H	6D	S17	S4	S8	S13	S16	S21

● HY1000-AM01: LCD LCD Dimensions

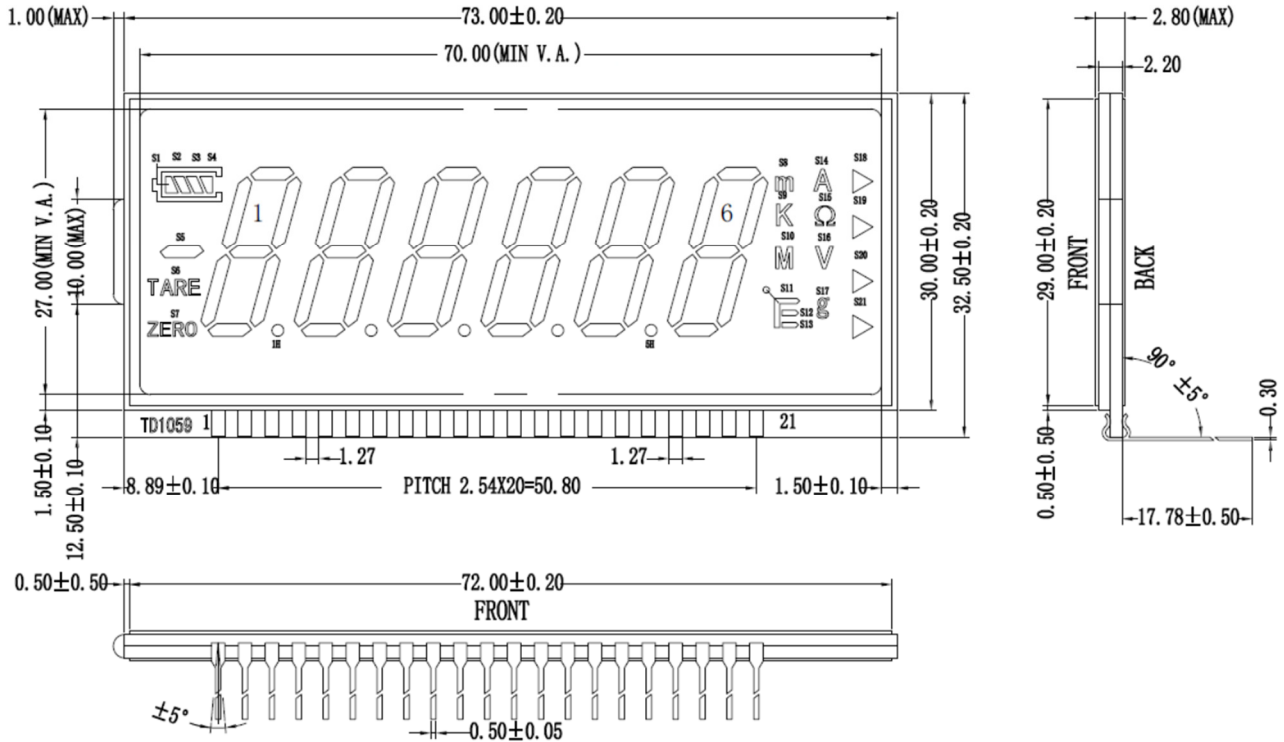

- HY10000-AM01: LCD COM/SEG Layout

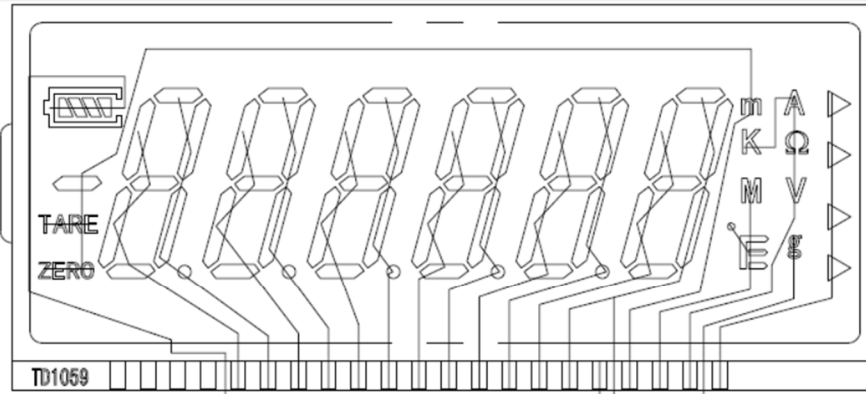

SEG

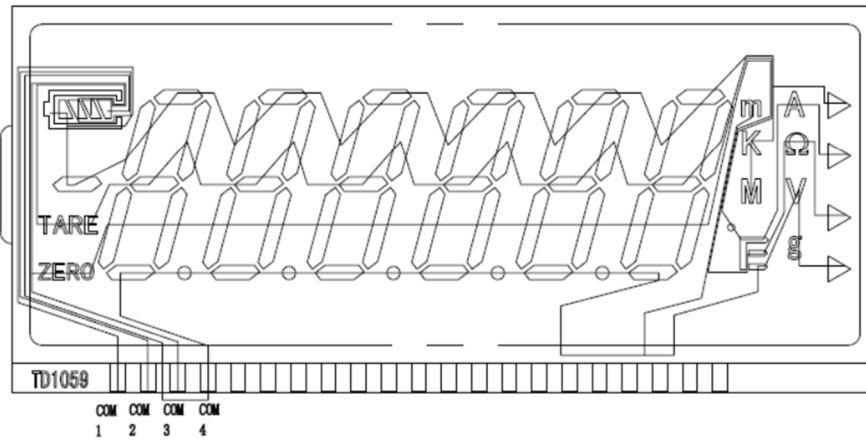

COM

4.6. HY16F Mini Link Debug Tool and Target Board Hardware Connection Steps

- Step1: Make sure that Target Board's J3 pin are shorted together.
- Step2: Connect the HY16F Mini Link Debug Tool EDM control Port and Target Board's EDM Port with the 5-wire EDM line.
- Step3: Use the USB Cable to connect to the HY16F Mini Link Debug Tool USB Port and the computer's USB port (Power LED will light on; The LCD panel start counting).
- Step4: After Step 1~3 (as shown in Figure 4-5), the hardware connection is completed.

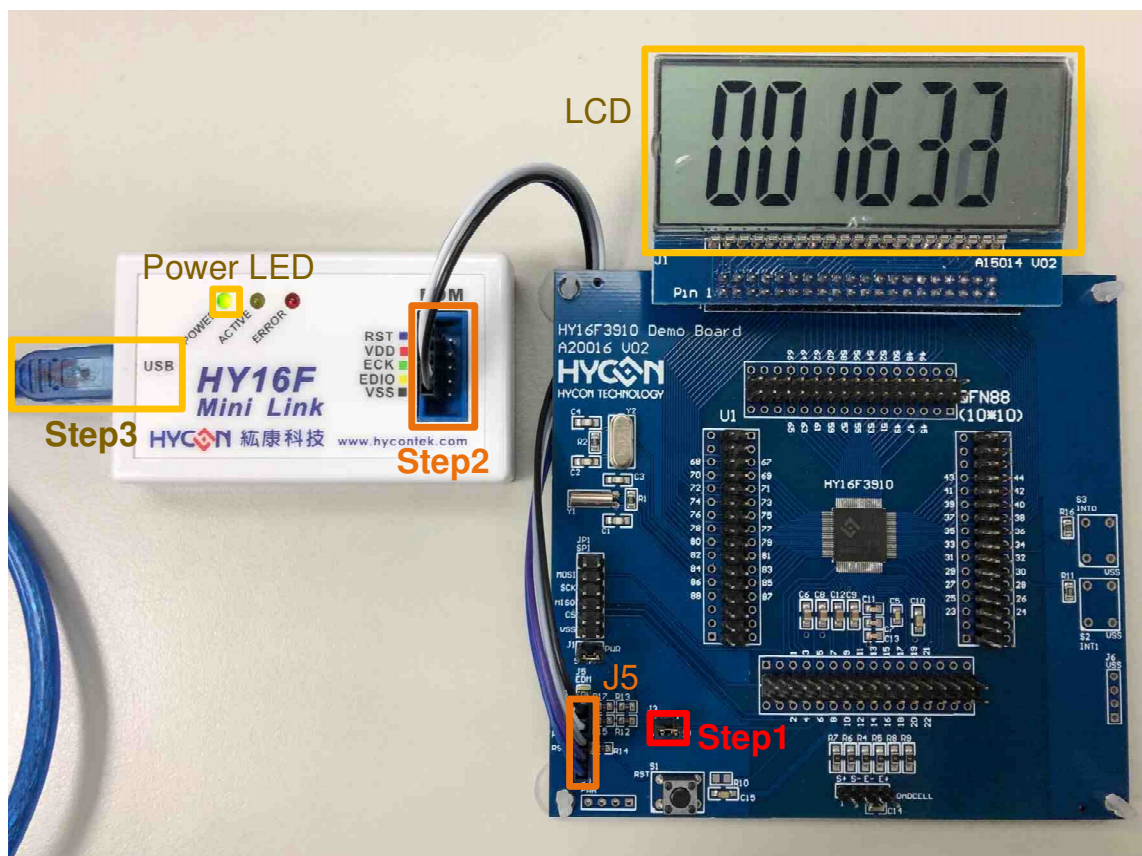

Figure 4-5

5. Hardware Connection Introduction

For driver install, please refer to HY16F Series, IDE Software User's Manual.

AICE USB driver program will install automatically when the software is installed.

For correct AICE connection status, libusb-win32 devices of AICE (which is HY16F Mini Link Debug Tool) will show up under PC device administrator.

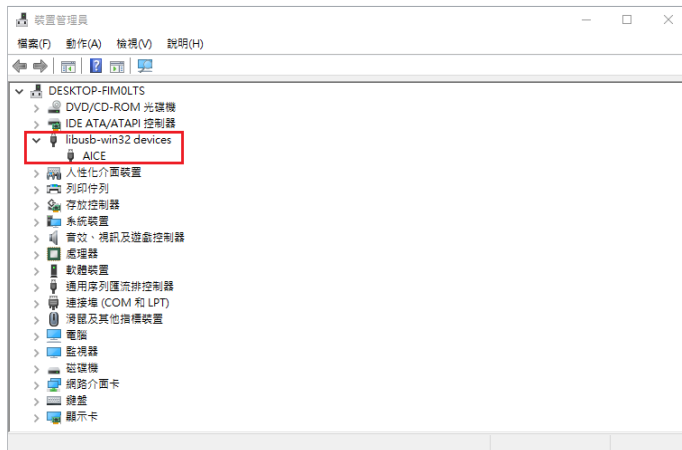

EDM connection test:

- (1) Connect the HY16F Mini Link Debug Tool to the Target Board .
- (2) Open the AndeSight IDE software.(Please refer to installation HY16F series IDE software installation steps)
 - (2.1) In the Target Manager: Local Targets window
 - (2.2) Select HY16F3910 by right-clicking(Select Connect Target via AICE)
 - (2.3) Successful connection appears HY16F3910 ICE-ICE:9904
 - (2.4-2.5) From the Console window, can see the version information of the Mini Link:Andes AICE-MINI v1.0.1

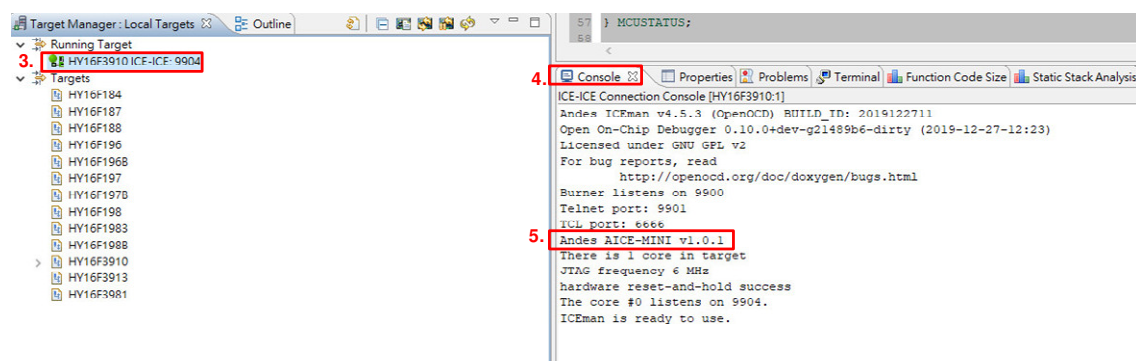
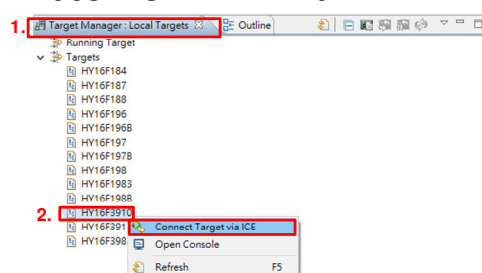

HY16F3910

IDE Hardware User's Manual

6. Revisions

The following describes the major changes made to the document, excluding the font and punctuation changes.

Version	Page	Date	Revision Summary
V02	ALL	2022/05/17	First edition