



HY2510 Series Data Sheet

1-Cell Lithium-ion/Lithium Polymer
Battery Packs Protection IC

Table of Contents

1.	GENERAL DESCRIPTION	4
2.	FEATURES	4
3.	APPLICATIONS	4
4.	BLOCK DIAGRAM.....	5
5.	ORDERING INFORMATION.....	6
6.	PIN CONFIGURATION AND PACKAGE MARKING INFORMATION	6
7.	ABSOLUTE MAXIMUM RATINGS	7
8.	ELECTRICAL CHARACTERISTICS	8
9.	TEST CONDITION AND CIRCUIT.....	12
9.1.	Test condition	12
9.2.	Test circuit	14
10.	EXAMPLE OF BATTERY PROTECTION IC CONNECTION.....	15
11.	DESCRIPTION OF OPERATION.....	16
11.1.	Normal Status.....	16
11.2.	Overcharge Status	16
11.3.	Overdischarge Status.....	17
11.4.	Discharge Overcurrent Status (Discharge Overcurrent & Short Circuit).....	17
11.5.	Charge Overcurrent Status	18
11.6.	0V Battery Charging Function “Unavailable”	18
11.7.	0V Battery Charging Function “Available”	18
12.	TIMING CHART	20
13.	CHARACTERISTICS (TYPICAL VALUE)	24
14.	PACKAGE INFORMATION AND LAND PATTERN DESIGN RECOMMENDATIONS.....	27
15.	TAPE & REEL INFORMATION.....	29
16.	REVISION RECORD.....	32

Attention :

1. HYCON Technology Corp. reserves the right to change the content of this datasheet without further notice. For most up-to-date information, please constantly visit our website: <http://www.hycontek.com> .
2. HYCON Technology Corp. is not responsible for problems caused by figures or application circuits narrated herein whose related industrial properties belong to third parties.
3. Specifications of any HYCON Technology Corp. products detailed or contained herein stipulate the performance, characteristics, and functions of the specified products in the independent state. We does not guarantee of the performance, characteristics, and functions of the specified products as placed in the customer's products or equipment. Constant and sufficient verification and evaluation is highly advised.
4. Please note the operating conditions of input voltage, output voltage and load current and ensure the IC internal power consumption does not exceed that of package tolerance. HYCON Technology Corp. assumes no responsibility for equipment failures that resulted from using products at values that exceed, even momentarily, rated values listed in products specifications of HYCON products specified herein.
5. Notwithstanding this product has built-in ESD protection circuit, please do not exert excessive static electricity to protection circuit.
6. Products specified or contained herein cannot be employed in applications which require extremely high levels of reliability, such as device or equipment affecting the human body, health/medical equipments, security systems, or any apparatus installed in aircrafts and other vehicles.
7. Despite the fact that HYCON Technology Corp. endeavors to enhance product quality as well as reliability in every possible way, failure or malfunction of semiconductor products may happen. Hence, users are strongly recommended to comply with safety design including redundancy and fire-precaution equipments to prevent any accidents and fires that may follow.
8. Use of the information described herein for other purposes and/or reproduction or copying without the permission of HYCON Technology Corp. is strictly prohibited.

1. General Description

The HY2510 Series is a protection IC for single-cell lithium-ion/lithium polymer rechargeable battery and it also comprises high-accuracy voltage detectors and delay circuits. These ICs are applicable to protect single-cell rechargeable lithium-ion/lithium polymer battery packs from overcharge, overdischarge and overcurrent.

2. Features

(1) High-accuracy voltage detection circuit

- Overcharge detection voltage 4.000V to 4.600V Accuracy: $\pm 20\text{mV}$
- Overcharge release voltage 3.600V to 4.600V Accuracy: $\pm 30\text{mV}$
- Overdischarge detection voltage 2.000V to 3.100V Accuracy: $\pm 50\text{mV}$
- Overdischarge release voltage 2.000V to 3.200V Accuracy: $\pm 50\text{mV}$
- Discharge overcurrent detection voltage 40mV to 250mV
 - ◆ 40mV~100mV Accuracy: $\pm 5\text{mV}$
 - ◆ >100mV~250mV Accuracy: $\pm 10\text{mV}$
- Charge overcurrent detection voltage -40mV to -250mV
 - ◆ -40mV~-100mV Accuracy: $\pm 5\text{mV}$
 - ◆ <-100mV~-250mV Accuracy: $\pm 10\text{mV}$
- Short-circuiting detection voltage 100mV to 500mV
 - ◆ 100mV~200mV Accuracy: $\pm 20\text{mV}$.
 - ◆ >200mV~500mV Accuracy: $\pm 10\%$

(2) Low current consumption

- Operation mode 3.0 μA typ., 6.0 μA max. (VDD=3.9V)
- Overdischarge Current Consumption 0.16 μA typ., 0.5 μA max. (VDD=2.0V)
- Power down Current 0.1 μA max. (VDD=2.0V)

(3) Delay times are generated by an internal circuit (external capacitors are unnecessary).

(4) "Auto over discharge recovery" or "Power Down function" is selectable.

(5) 0 V battery charge function is selectable: "Available" or "Unavailable"

(6) High-withstanding-voltage: CS pin and OC pin: Absolute maximum rating = 20 V.

(7) Wide operation temperature range: -40°C to $+85^{\circ}\text{C}$

(8) Package: SON-1.6 *1.6-6L, SOT-23-6

(9) Halogen-free, green package

3. Applications

- 1-cell lithium-ion rechargeable battery packs
- 1-cell lithium polymer rechargeable battery packs

4. Block Diagram

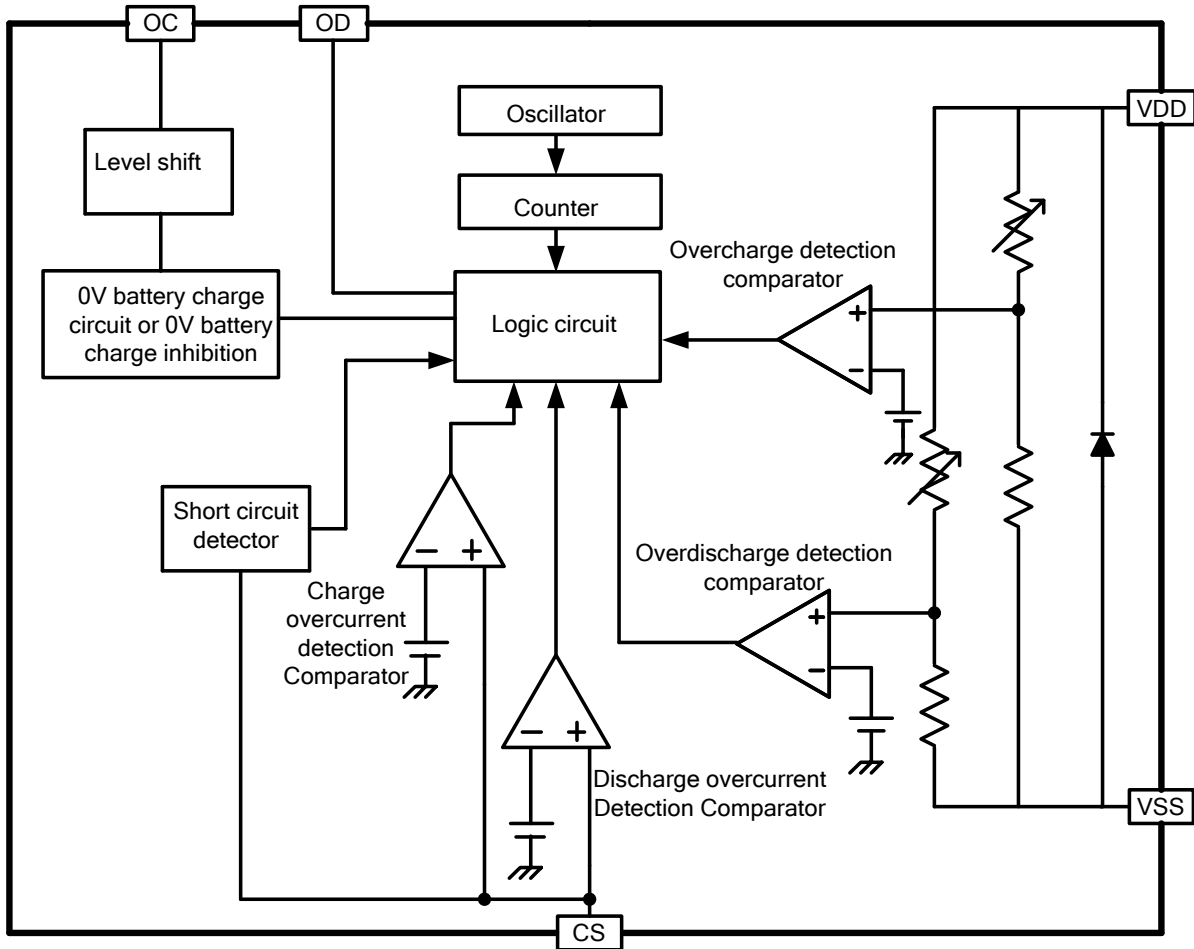

5. Ordering Information

HY2510\$\$- # % &

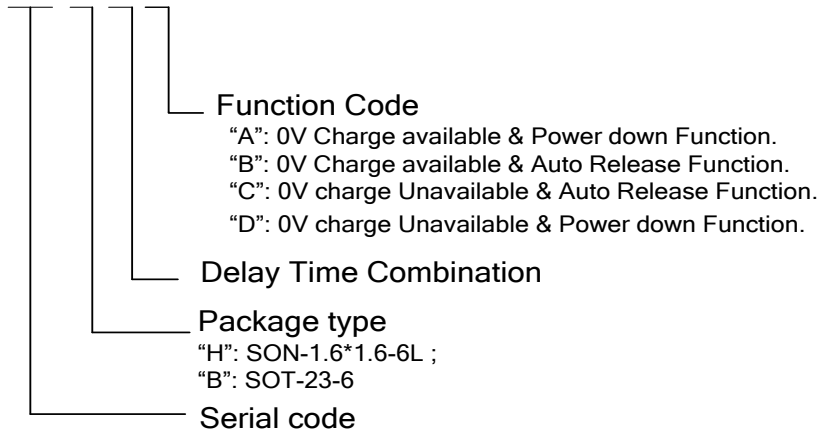

6. Pin Configuration and Package Marking Information

Table 1 SON-1.6*1.6-6L

Pin No.	Symbol	Description
1	NC	No connection.
2	OC	MOSFET gate connection pin for charge control
3	OD	MOSFET gate connection pin for discharge control
4	VSS	Ground pin
5	VDD	Power supply pin
6	CS	Input pin for current sense, charger detect pin

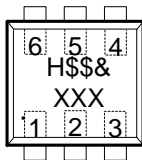

H: Product name Code.
 \$\$: Serial Code.
 &: Function Code.
 XXX: Traceability Code

Table 2 SOT-23-6

Pin No.	Symbol	Description
1	OD	MOSFET gate connection pin for discharge control
2	CS	Input pin for current sense, charger detect pin
3	OC	MOSFET gate connection pin for charge control
4	NC	No connection.
5	VDD	Power supply pin
6	VSS	Ground pin

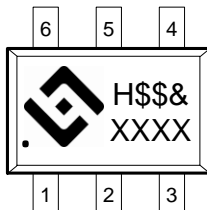

H: Product Name Code.
 \$\$: Serial Code.
 &: Function Code.
 XXXX: Traceability Code.

7. Absolute Maximum Ratings

Table3 Absolute Maximum Ratings (VSS=0V, Ta=25°C unless otherwise specified)

Item	Symbol	Rating	Unit
Input voltage between VDD and VSS pin	V _{DD}	VSS-0.3 to VSS+9	V
OC output pin voltage	V _{OC}	VDD-20 to VDD+0.3	V
OD output pin voltage	V _{OD}	VSS-0.3 to VDD+0.3	V
CS input pin voltage	V _{CS}	VDD-20 to VDD+0.3	V
Operating Temperature Range	T _{OP}	-40 to +85	°C
Storage Temperature Range	T _{ST}	-40 to +125	°C
Power dissipation	P _D	250	mW

8. Electrical Characteristics

Table 4 Electrical Characteristics (VSS=0V, Ta=25°C unless otherwise specified)

Item	Symbol	Condition	Min.	Typ.	Max.	Unit
SUPPLY POWER RANGE						
Operating voltage between VDD pin and VSS pin	V _{DSOP1}	-	1.5	-	6.0	V
Operating voltage between VDD pin and CS pin	V _{DSOP2}	-	1.5	-	20	V
INPUT CURRENT(with Power-down Function)						
Supply Current	I _{DD}	V _{DD} =3.9V	-	3.0	6.0	μA
Power-Down Current	I _{PD}	V _{DD} =2.0V	-	-	0.1	μA
INPUT CURRENT(with Auto Overdischarge Recovery Function)						
Supply Current	I _{DD}	V _{DD} =3.9V	-	3.0	6.0	μA
Overdischarge Current Consumption	I _{OD}	V _{DD} =2.0V	-	0.16	0.5	μA
DETECTION VOLTAGE						
Overcharge Detection Voltage	V _{CU}	4.0V to 4.6V adjustable	V _{CU} -0.02	V _{CU}	V _{CU} +0.02	V
Overcharge Release Voltage	V _{CR}	3.6V to 4.6V adjustable	V _{CR} -0.03 V _{CR} -0.03	V _{CR}	V _{CR} +0.03 V _{CR} +0.02	V
Overdischarge Detection Voltage	V _{DL}	2.0V to 3.1V adjustable	V _{DL} -0.05	V _{DL}	V _{DL} +0.05	V
Overdischarge Release Voltage	V _{DR}	2.0V to 3.2V adjustable	V _{DR} -0.05	V _{DR}	V _{DR} +0.05	V
Discharge Overcurrent Detection Voltage	V _{DIP}	V _{DD} =3.6V	40mV~100mV >100mV~250mV	V _{DIP} -5 V _{DIP} -10	V _{DIP} +5 V _{DIP} +10	mV
Charge overcurrent detection voltage	V _{CIP}	V _{DD} =3.6V	-40mV~-100mV <-100mV~-250mV	V _{CIP} -5 V _{CIP} -10	V _{CIP} +5 V _{CIP} +10	mV
Short Circuit Detection Voltage	V _{SIP}	V _{DD} =3.2V	100mV~200mV >200mV~500mV	V _{SIP} -20 V _{SIP} X0.9	V _{SIP} +20 V _{SIP} X1.1	mV
DELAY TIME						
Overcharge Delay Time	T _{OC}	V _{DD} =4.0V→4.6V	T _{OC} X0.8	T _{OC}	T _{OC} X1.2	ms
Overcharge Release Delay Time	T _{OCR}	V _{DD} =4.6V→4.0V	T _{OCR} X0.8	T _{OCR}	T _{OCR} X1.2	ms
Overdischarge Delay Time	T _{OD}	V _{DD} =3.6V→2.0V	T _{OD} X0.8	T _{OD}	T _{OD} X1.2	ms
Overdischarge Release Delay Time	T _{ODR}	V _{DD} =2.0V→3.6V	T _{ODR} X0.7	T _{ODR}	T _{ODR} X1.3	ms
Discharge Overcurrent Delay Time	T _{DIP}	V _{DD} =3.6V, CS=0V→V _{DIP}	T _{DIP} X0.8	T _{DIP}	T _{DIP} X1.2	ms
Discharge Overcurrent Release Delay Time	T _{DIPR}	V _{DD} =3.6V, CS=V _{DIP} →0V	T _{DIPR} X0.8	T _{DIPR}	T _{DIPR} X1.2	ms
Charge Overcurrent Delay Time	T _{CIP}	V _{DD} =3.6V, CS=0V→V _{CIP}	T _{CIP} X0.8	T _{CIP}	T _{CIP} X1.2	ms
Charge Overcurrent Release Delay Time	T _{CIPR}	V _{DD} =3.6V, CS=V _{CIP} →0V	T _{CIPR} X0.8	T _{CIPR}	T _{CIPR} X1.2	ms
Short Circuit Delay Time	T _{SIP}	V _{DD} =3.2V, CS=0V→0.6V	T _{SIP} -150	T _{SIP}	T _{SIP} +150	μs
CONTROL OUTPUT VOLTAGE(OD&OC)						
OD Pin Output "H" Voltage	V _{DH}		V _{DD} -0.1	V _{DD} -0.02	-	V
OD Pin Output "L" Voltage	V _{DL}		-	0.1	0.5	V
OC Pin Output "H" Voltage	V _{CH}		V _{DD} -0.1	V _{DD} -0.02	-	V
OC Pin Output "L" Voltage	V _{CL}		-	0.1	0.5	V
0V BATTERY CHARGE FUNCTION						
0V battery charge inhibition battery voltage	V _{0IN}	0V battery charge function "Unavailable"	1.0	1.3	1.5	V
0V battery charge starting charger voltage	V _{0ch}	0V battery charge function "Available"	0.0	0.7	1.2	V

Tale 5 Electrical Characteristics (VSS=0V, Ta=-20°C ~60°C)

Item	Symbol	Condition	Min.	Typ.	Max.	Unit
SUPPLY POWER RANGE						
Operating voltage between VDD pin and VSS pin	V _{D SOP1}	-	1.5	-	6.0	V
Operating voltage between VDD pin and CS pin	V _{D SOP2}	-	1.5	-	20	V
INPUT CURRENT(with Power-down Function)						
Supply Current	I _{DD}	V _{DD} =3.9V	-	3.0	6.0	μA
Power-Down Current	I _{PD}	V _{DD} =2.0V	-	-	0.1	μA
INPUT CURRENT(with Auto Overdischarge Recovery Function)						
Supply Current	I _{DD}	V _{DD} =3.9V	-	3.0	6.0	μA
Overdischarge Current Consumption	I _{OD}	V _{DD} =2.0V	-	0.16	0.5	μA
DETECTION VOLTAGE						
Overcharge Detection Voltage	V _{CU}	4.0V to 4.6V adjustable	V _{CU} -0.025	V _{CU}	V _{CU} +0.025	V
Overcharge Release Voltage	V _{CR}	3.6V to 4.6V adjustable	V _{CR} ≠V _{CU}	V _{CR} -0.035	V _{CR}	V _{CR} +0.035
			V _{CR} =V _{CU}	V _{CR} -0.035		V _{CR} +0.025
Overdischarge Detection Voltage	V _{DL}	2.0V to 3.1V adjustable	V _{DL} -0.055	V _{DL}	V _{DL} +0.055	V
Overdischarge Release Voltage	V _{DR}	2.0V to 3.2V adjustable	V _{DR} -0.055	V _{DR}	V _{DR} +0.055	V
Discharge Overcurrent Detection Voltage	V _{DIP}	V _{DD} =3.6V	40mV~100mV	V _{DIP} -10	V _{DIP}	V _{DIP} +10
			>100mV~250mV	V _{DIP} -15		V _{DIP} +15
Charge overcurrent detection voltage	V _{CIP}	V _{DD} =3.6V	-40mV~-100mV	V _{CIP} -15	V _{CIP}	V _{CIP} +15
			<-100mV~-250mV	V _{CIP} -20		V _{CIP} +20
Short Circuit Detection Voltage	V _{SIP}	V _{DD} =3.2V	100mV~200mV	V _{SIP} -25	V _{SIP}	V _{SIP} +25
			>200mV~500mV	V _{SIP} x0.85		V _{SIP} x1.15
DELAY TIME						
Overcharge Delay Time	T _{OC}	V _{DD} =4.0V→4.6V	T _{OC} x0.7	T _{OC}	T _{OC} x1.35	ms
Overcharge Release Delay Time	T _{OCR}	V _{DD} =4.6V→4.0V	T _{OCR} x0.7	T _{OCR}	T _{OCR} x1.35	ms
Overdischarge Delay Time	T _{OD}	V _{DD} =3.6V→2.0V	T _{OD} x0.7	T _{OD}	T _{OD} x1.35	ms
Overdischarge Release Delay Time	T _{ODR}	V _{DD} =2.0V→3.6V	T _{ODR} x0.5	T _{ODR}	T _{ODR} x1.5	ms
Discharge Overcurrent Delay Time	T _{DIP}	V _{DD} =3.6V, CS=0V→V _{DIP}	T _{DIP} x0.7	T _{DIP}	T _{DIP} x1.35	ms
Discharge Overcurrent Release Delay Time	T _{DIPR}	V _{DD} =3.6V, CS=V _{DIP} →0V	T _{DIPR} x0.7	T _{DIPR}	T _{DIPR} x1.35	ms
Charge Overcurrent Delay Time	T _{CIP}	V _{DD} =3.6V, CS=0V→V _{CIP}	T _{CIP} x0.7	T _{CIP}	T _{CIP} x1.35	ms
Charge Overcurrent Release Delay Time	T _{CIPR}	V _{DD} =3.6V, CS=V _{CIP} →0V	T _{CIPR} x0.7	T _{CIPR}	T _{CIPR} x1.35	ms
Short Circuit Delay Time	T _{SIP}	V _{DD} =3.2V, CS=0V→0.6V	T _{SIP} -200	T _{SIP}	T _{SIP} +200	μs
CONTROL OUTPUT VOLTAGE(OD&OC)						
OD Pin Output "H" Voltage	V _{DH}		V _{DD} -0.1	V _{DD} -0.02	-	V
OD Pin Output "L" Voltage	V _{DL}		-	0.1	0.5	V
OC Pin Output "H" Voltage	V _{CH}		V _{DD} -0.1	V _{DD} -0.02	-	V
OC Pin Output "L" Voltage	V _{CL}		-	0.1	0.5	V
0V BATTERY CHARGE FUNCTION						
0V battery charge inhibition battery voltage	V _{0IN}	0V battery charge function "Unavailable"	1.0	1.3	1.5	V
0V battery charge starting charger voltage	V _{0ch}	0V battery charge function "Available"	0.0	0.7	1.2	V

Note: Since products are not screened at high and low temperature, the specification for this temperature range is guaranteed by design, not tested in production.

Tale 6 Electrical Characteristics (VSS=0V, Ta=-40°C ~85°C)

Item	Symbol	Condition	Min.	Typ.	Max.	Unit
SUPPLY POWER RANGE						
Operating voltage between VDD pin and VSS pin	V _{DSOP1}		1.5	-	6.0	V
Operating voltage between VDD pin and CS pin	V _{DSOP2}		1.5	-	20	V
INPUT CURRENT(with Power-down Function)						
Supply Current	I _{DD}	V _{DD} =3.9V	-	3.0	6.0	μA
Power-Down Current	I _{PD}	V _{DD} =2.0V	-	-	0.1	μA
INPUT CURRENT(with Auto Overdischarge Recovery Function)						
Supply Current	I _{DD}	V _{DD} =3.9V	-	3.0	6.0	μA
Overdischarge Current Consumption	I _{OD}	V _{DD} =2.0V	-	0.16	0.5	μA
DETECTION VOLTAGE						
Overcharge Detection Voltage	V _{CU}	4.0V to 4.6V adjustable	V _{CU} -0.035	V _{CU}	V _{CU} +0.035	V
Overcharge Release Voltage	V _{CR}	3.6V to 4.6V adjustable	V _{CR} ≠V _{CU}	V _{CR}	V _{CR} +0.045	V
			V _{CR} =V _{CU}		V _{CR} -0.045	
Overdischarge Detection Voltage	V _{DL}	2.0V to 3.1V adjustable	V _{DL} -0.065	V _{DL}	V _{DL} +0.065	V
Overdischarge Release Voltage	V _{DR}	2.0V to 3.2V adjustable	V _{DR} -0.065	V _{DR}	V _{DR} +0.065	V
Discharge Overcurrent Detection Voltage	V _{DIP}	V _{DD} =3.6V	40mV~100mV	V _{DIP}	V _{DIP} +10	mV
			>100mV~250mV		V _{DIP} -15	
Charge overcurrent detection voltage	V _{CIP}	V _{DD} =3.6V	-40mV~-100mV	V _{CIP}	V _{CIP} +15	mV
			<-100mV~-250mV		V _{CIP} -20	
Short Circuit Detection Voltage	V _{SIP}	V _{DD} =3.2V	100mV~200mV	V _{SIP}	V _{SIP} +25	mV
			>200mV~500mV		V _{SIP} x0.85	
DELAY TIME						
Overcharge Delay Time	T _{OC}	V _{DD} =4.0V→4.6V	T _{OC} x0.6	T _{OC}	T _{OC} x1.6	ms
Overcharge Release Delay Time	T _{OCR}	V _{DD} =4.6V→4.0V	T _{OCR} x0.6	T _{OCR}	T _{OCR} x1.6	ms
Overdischarge Delay Time	T _{OD}	V _{DD} =3.6V→2.0V	T _{OD} x0.6	T _{OD}	T _{OD} x1.6	ms
Overdischarge Release Delay Time	T _{ODR}	V _{DD} =2.0V→3.6V	T _{ODR} x0.4	T _{ODR}	T _{ODR} x1.6	ms
Discharge Overcurrent Delay Time	T _{DIP}	V _{DD} =3.6V, CS=0V→V _{DIP}	T _{DIP} x0.6	T _{DIP}	T _{DIP} x1.6	ms
Discharge Overcurrent Release Delay Time	T _{DIPR}	V _{DD} =3.6V, CS=V _{DIP} →0V	T _{DIPR} x0.6	T _{DIPR}	T _{DIPR} x1.6	ms
Charge Overcurrent Delay Time	T _{CIP}	V _{DD} =3.6V, CS=0V→V _{CIP}	T _{CIP} x0.6	T _{CIP}	T _{CIP} x1.6	ms
Charge Overcurrent Release Delay Time	T _{CIPR}	V _{DD} =3.6V, CS=V _{CIP} →0V	T _{CIPR} x0.6	T _{CIPR}	T _{CIPR} x1.6	ms
Short Circuit Delay Time	T _{SIP}	V _{DD} =3.2V, CS=0V→0.6V	T _{SIP} -250	T _{SIP}	T _{SIP} +250	μs
CONTROL OUTPUT VOLTAGE(OD&OC)						
OD Pin Output "H" Voltage	V _{DH}		V _{DD} -0.1	V _{DD} -0.02	-	V
OD Pin Output "L" Voltage	V _{DL}		-	0.1	0.5	V
OC Pin Output "H" Voltage	V _{CH}		V _{DD} -0.1	V _{DD} -0.02	-	V
OC Pin Output "L" Voltage	V _{CL}		-	0.1	0.5	V

0V BATTERY CHARGE FUNCTION						
0V battery charge inhibition battery voltage	V_{0IN}	0V battery charge function "Unavailable"	1.0	1.3	1.5	V
0V battery charge starting charger voltage	V_{0ch}	0V battery charge function "Available"	0.0	0.7	1.2	V

Note: Since products are not screened at high and low temperature, the specification for this temperature range is guaranteed by design, not tested in production.

9. Test condition and circuit

9.1. Test condition

9.1.1 Supply Current (Test circuit 1)

Apply 3.9V to V1 with SW=ON (Normal mode). The VDD terminal current in this state is Supply Current (I_{DD}).

9.1.2 Power-down current or Overdischarge Current Consumption (Test circuit 1)

Apply 2.0V to V1 with SW=OFF (Overdischarge mode). The VDD terminal current in this state is Power-down current (I_{PD}) or overdischarge current consumption (I_{OD}).

9.1.3 Overcharge Detection Voltage, Overcharge Release Voltage (Test circuit 2)

Apply V1=3.6V with V2=0V, increase V1 voltage gradually from normal mode. Overcharge Detection Voltage (V_{CU}) is the V1 voltage when V_{OC} turns to "L" level from "H" level.

Setting V2=0V, Overcharge Release Voltage (V_{CR}) is defined as the voltage V1 at which V_{OC} turns to "H" level from "L" level when the voltage V1 is gradually decreased.

9.1.4 Overdischarge Detection Voltage, Overdischarge Release Voltage (Test circuit 2)

Apply V2=0V, and V1 is gradually decreased from normal mode. Overdischarge Detection Voltage (V_{DL}) is the voltage V1 when V_{OD} turns to "L" level from "H" level.

Overdischarge Release Voltage (V_{DR}) is defined as the voltage V1 at which V_{OD} turns to "H" from "L" level when the voltage V1 is gradually increased.

9.1.5 Discharge Overcurrent Detection Voltage (Test circuit 2)

Apply 3.6V to V1, 0V to V2 and increase V2 voltage gradually from normal mode. Discharge Overcurrent Detection Voltage (V_{DIP}) is the V2 voltage when V_{OD} turns "L" level from "H" level.

9.1.6 Charge Overcurrent Detection Voltage (Test circuit 2)

Apply 3.6V to V1, 0V to V2 and decrease V2 voltage gradually from Normal mode. Charge Overcurrent Detection Voltage (V_{CIP}) is the V2 voltage when V_{OC} turns to "L" level from "H" level.

9.1.7 Short Circuit Detection Voltage (Test circuit 2)

Apply 3.2V to V1, 0V to V2 and increase V2 voltage gradually from normal mode. Short Circuit Detection Voltage (V_{SIP}) is defined as the voltage V2 whose delay time for changing V_{OD} from "H" to "L" in Short Circuit Detection Delay Time (T_{SIP}).

9.1.8 Overcharge detection delay time, Overcharge release delay time (Test circuit 3)

Apply 0V to V2, and increase V1 from 4.0V (Normal mode) to 4.6V. Overcharge Detection Delay Time (T_{OC}) is the time from V1 exceeds Overcharge Detection Voltage until V_{OC} turns to "L".

Apply 0V to V2, and decrease V1 from 4.6V (Overcharge mode) to 4.0V. Overcharge Release Delay Time (T_{OCR}) is the time from V1 falls below Overcharge Release Voltage until V_{OC} turns "H" level.

9.1.9 Overdischarge Detection Delay Time, Overdischarge Release Delay Time (Test circuit 3)

Apply 0V to V2, and decrease V1 from 3.6V (Normal mode) to 2.0V. Overdischarge Detection Delay Time (T_{OD}) is the time from V1 falls below Overdischarge Detection

Voltage until V_{OD} turns to "L".

Apply 0V to V2, and increase V1 from 2.0V (Overdischarge mode) to 3.6V. Overdischarge Release Delay Time (T_{ODR}) is the time from V1 exceeds Overdischarge Release Voltage until V_{OD} turns to "H".

9.1.10 Discharge Overcurrent Delay Time, Discharge Overcurrent Release Delay Time (Test circuit 3)

Apply 3.6V to V1, and increase V2 from 0V (Normal mode) to Discharge Overcurrent Detection Voltage (V_{DIP}). Discharge Overcurrent Delay Time (T_{DIP}) is the time from V2 exceeds Discharge Overcurrent Detection Voltage until V_{OD} turns to "L".

Apply 3.6V to V1, and decrease V2 from Discharge Overcurrent Detection Voltage (V_{DIP}) to 0V. Discharge Overcurrent Release Delay Time (T_{DIPR}) is the time from V2 falls below Discharge Overcurrent Release Voltage until V_{OD} turns to "H".

9.1.11 Charge Overcurrent Delay Time, Charge Overcurrent Release Delay Time (Test circuit 3)

Apply 3.6V to V1, and decrease V2 from 0V (Normal mode) to Charge Overcurrent Detection Voltage (V_{CIP}). Charge Overcurrent Delay Time (T_{CIP}) is the time from V2 falls below Charge Overcurrent detection voltage until V_{OC} turns to "L".

Apply 3.6V to V1, and increase V2 from Charge Overcurrent Detection Voltage (V_{CIP}) to 0V. Charge Overcurrent release delay time (T_{CIPR}) is the time from V2 exceeds Charge overcurrent release voltage until V_{OC} turns to "H".

9.1.12 Short Circuit Delay Time, Short Circuit Release Delay Time (Test circuit 3)

Apply 3.2V to V1, and increase V2 from 0V (Normal mode) to Short Circuit Detection Voltage (V_{SIP}). Short Circuit Delay Time (T_{SIP}) is the time from V2 exceeds Short Circuit Detection Voltage until V_{OD} turns to "L".

Apply 3.2V to V1, and decrease V2 from 3.2V (Short Circuit mode) to 0V. Short Circuit Release Delay Time (T_{SIPR}) is the time from V2 falls below Short Circuit Release Voltage until V_{OD} turns to "H".

9.1.13 0V battery charge inhibition battery voltage (Test circuit 2)

The 0V battery charge inhibition battery voltage (V_{OIN}) is defined as the voltage V1 at which V_{OC} turns to "L" ($V_{OC} = V_{CS}$) when the voltage V1 is gradually decreased from the setting condition of $V1=2.0V$, $V2=-4.0V$.

9.1.14 0V battery charge starting charger voltage (Test circuit 2)

The 0V battery charge starting charger voltage (V_{Och}) is defined as the voltage V1 at which V_{OC} turns to "H" ($V_{OC} = V_{SS}$) when the voltage V2 is gradually decreased from the setting condition of $V1=0V$, $V2=-1.2V$.

9.2. Test circuit

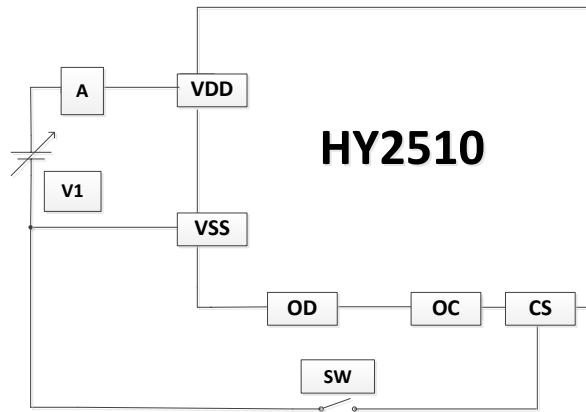

Test circuit 1

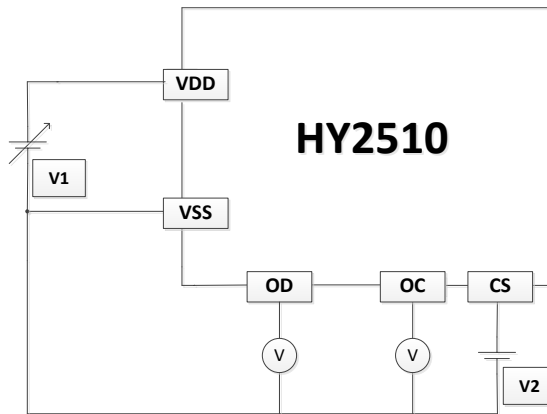

Test circuit 2

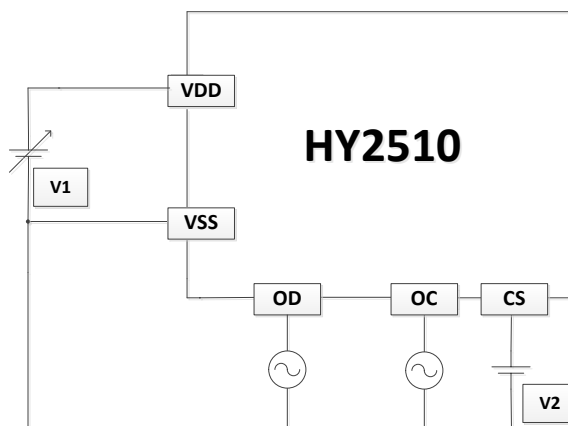

Test circuit 3

10. Example of Battery Protection IC Connection

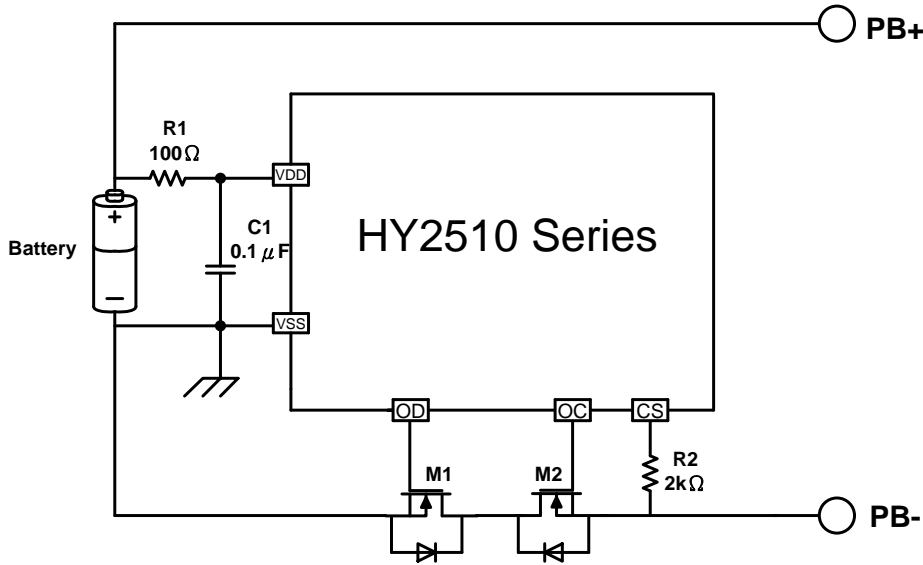

Symbol	Device Name	Purpose	Min.	Typ.	Max.	Remark
R1	Resistor	limit current, stabilize VDD and strengthen ESD protection	100Ω	100Ω	470Ω	*1
R2	Resistor	limit current	1kΩ	2kΩ	2.2kΩ	*2
C1	Capacitor	stabilize VDD	0.01μF	0.1μF	1.0μF	*3
M1	N-MOSFET	Discharge control	-	-	-	*4
M2	N-MOSFET	Charge control	-	-	-	*5

- *1. R1 should be as small as possible to avoid lowering the overcharge detection accuracy due to current consumption. When a charger is connected in reversed, the current flows from the charger to the IC. At this time, if R1 is connected to high resistance, the voltage between VDD pin and VSS pin may exceed the absolute maximum rating.
- *2. If R2 has a resistance higher than 2.2kΩ, the charging current may not be cut when a high-voltage charger is connected. Please select as large a resistance as possible to prevent current when a charger is connected in reversed.
- *3. C1 will stabilize the supply voltage of VDD, the value of C1 should be equal to or more than 0.01μF.
- *4. If a FET with a threshold voltage equal to or higher than the overdischarge detection voltage is applied, discharging may be stopped before overdischarge is detected.
- *5. If the withstanding voltage between the gate and source is lower than the charger voltage, the FET may be destroyed.

Caution :

1. The above constants may be changed without notice, please download the most up-to-date datasheet on our website. <http://www.hycontek.com>
2. It is advised to perform thorough evaluation and test if peripheral devices need to be adjusted.

11. Description of Operation

11.1. Normal Status

The IC monitors the voltage of the battery connected between the VDD pin and VSS pin and the voltage difference between the CS pin and VSS pin to control charging and discharging.

When the battery voltage is in the range from overdischarge detection voltage (V_{DL}) to overcharge detection voltage (V_{CU}), and the CS pin voltage is in the range from the charge overcurrent detection voltage (V_{CIP}) to discharge overcurrent detection voltage (V_{DIP}), the IC turns both the charging and discharging control MOSFET on. Such status is referred to as the normal status, when in this status, charging and discharging can both be carried out freely.

Notice:

In case of discharge function may not be carried out when The IC connected battery, in this case, connecting a charger to reset and normal operating status is returned.

11.2. Overcharge Status

When the battery voltage is higher than the overcharge detection voltage (V_{CU}) during charging under the normal status and the sustaining time of such status is longer than the overcharge detection delay time (T_{OC}), The IC will turns the charging control MOSFET off (OC pin) to stop charging .This condition is called the overcharge status.

The overcharge status can be released by the following two cases:

Condition: disconnect charger

- (1) When the battery voltage is lowers than or equal to the overcharge release voltage (V_{CR}), the IC turns the charging MOSFET off and return to normal status.
- (2) When the load is connected, the discharge current will pass through parasitical diode of charging control MOSFET. At this time, CS pin will detect "Diode forward voltage drop (V_f)". When CS pin voltage rises higher than discharge overcurrent detection voltage (V_{DIP}) and battery voltage lowers than overcharge detection voltage (V_{CU}), the overcharge status will be released and return to normal status.

Caution:

When a charger is connected after overcharge detection, the overcharge status is not released even if the battery voltage is below overcharge release voltage (V_{CR}). The overcharge status is released when the CS pin voltage goes over the charge overcurrent detection voltage (V_{CIP}) by removing the charger.

11.3. Overdischarge Status

11.3.1. Products with Power-down Function

When the battery voltage falls below than the overdischarge detection voltage (V_{DL}) during discharging in the normal status and the detection continues longer than the overdischarge detection delay time (T_{OD}), the IC will turn the discharging control MOSFET off (OD pin) so as to stop discharging. This condition is called the overdischarge status.

When the MOSFET is off, CS pin voltage is pulled up by the resistor to VDD in the IC, at this time, the power consumption is reduced to the lowest. This condition is called the “SLEEP MODE”.

The overdischarge status will be released by two cases:

- (1) When CS pin voltage is equal to or lower than the charge overcurrent detection voltage (V_{CIP}) by charging and the VDD pin voltage is higher than the overdischarge detection voltage (V_{DL}).
- (2) When CS pin voltage is equal to or higher than the charge overcurrent detection voltage (V_{CIP}) by charging and the VDD pin voltage is higher than the overdischarge release voltage (V_{DR}).

11.3.2. Products with Auto Overdischarge Recovery Function

When the battery voltage falls below than the overdischarge detection voltage (V_{DL}) during discharging in the normal status and the detection continues longer than the overdischarge detection delay time (T_{OD}), the IC will turn the discharging control MOSFET off (OD pin) so as to stop discharging. This condition is called the overdischarge status.

The overdischarge status will be released by three cases:

- (1) When CS pin voltage is equal to or lower than the charge overcurrent detection voltage (V_{CIP}) by charging and the VDD pin voltage is higher than the overdischarge detection voltage (V_{DL}).
- (2) When CS pin voltage is equal to or higher than the charge overcurrent detection voltage (V_{CIP}) by charging and the VDD pin voltage is higher than the overdischarge release voltage (V_{DR}).
- (3) Without connecting a charger, if the VDD pin voltage is higher than overdischarge release voltage (V_{DR}), the overdischarge status will be released, namely Auto Overdischarge Recovery Function.

11.4. Discharge Overcurrent Status (Discharge Overcurrent & Short Circuit)

Under normal condition, The IC continuously monitors the discharge current by sensing the voltage of CS pin. If the voltage of CS pin exceeds the overcurrent detection voltage (V_{DIP}) and the sustaining time of such status is longer than the overcurrent delay time (T_{DIP}), the output voltage on OD pin of IC becomes low level from high level, such that the MOSFET for discharging control is switched off, This status is called the discharge overcurrent status.

If the voltage of CS pin exceeds the short circuit detection voltage (V_{SIP}) and the sustaining time of such status is longer than the short circuit delay time (T_{SIP}), the output voltage on OD pin of IC becomes low level from high level, such that the MOSFET for discharging control is switched off. This condition is called the short circuit status.

When the impedance between PB+ and PB- is higher than discharge overcurrent and short circuit release impedance (25k Ω typ.), the discharge overcurrent status and short circuit status will be released and return to normal operation status. In addition, if the impedance between PB+ and PB- is less than discharge overcurrent and short circuit release impedance, CS pin voltage will lower than overcurrent detection voltage (V_{DIP}) after the charger is connected, discharge overcurrent status and short circuit status will be released and return to normal operation status.

Caution:

- (1) If the charger is connected and polarity direction is in reversed, the current direction is the same as discharge current in the circuit. If CS pin voltage goes higher than overcurrent detection voltage (V_{DIP}), it will enter into discharge overcurrent protection status to block out in-circuit current.

11.5. Charge Overcurrent Status

When a battery is in the normal status, the voltage of the CS pin is lower than the charge overcurrent detection voltage (V_{CIP}) and the sustaining time of such status is longer than the charge overcurrent detection delay time (T_{CIP}), The IC will turn the charging control MOSFET off (OC pin) to stop charging. This status is called the charge overcurrent status.

This IC will be restored to the normal status from the charge overcurrent status when the voltage at the CS pin returns to charge overcurrent detection voltage (V_{CIP}) or higher by removing the charger.

11.6. 0V Battery Charging Function “Unavailable”

When a battery that is internally short-circuited (0V battery) is connected, the unavailable 0V charging function will prohibit recharging. When the battery voltage equals to the 0V battery charge inhibition battery voltage (V_{0IN}) or lower, the charging control MOSFET gate is fixed to the PB- pin voltage to prohibit charging. When the battery voltage equals to the 0V battery charge inhibition battery voltage (V_{0IN}) or higher, charging can be implemented.

Caution

Some battery provides do not recommend charging for a completely self-discharged battery. Please ask the battery provider to determine whether to enable or prohibit the 0V battery charging function.

11.7. 0V Battery Charging Function “Available”

This function is used to recharge a connected battery which voltage is 0V due to self-discharge.

When the 0V battery charge starting charger voltage (V_{0ch}) or a higher voltage is applied between the battery+ (PB+) and battery- (PB-) pins by connecting a charger, the charging control MOSFET gate is fixed to the VDD pin voltage.

When the voltage between the gate and the source of the charging control MOSFET becomes equal to or higher than the turn on voltage due to the charger voltage, the charging control MOSFET is

turned on to initiate charging. At this time, the discharging control MOSFET is off and the charging current flows through the internal parasitic diode in the discharging control MOSFET. When the battery voltage becomes equal to or higher than overdischarge detection voltage (V_{DL}), The IC will enter into the normal status.

Caution

Some battery provides do not recommend charging for a completely self-discharged battery. Please ask the battery provider to determine whether to enable or prohibit the 0V battery charging function.

12. Timing Chart

12.1 Overcharge Detection, Overdischarge Detection

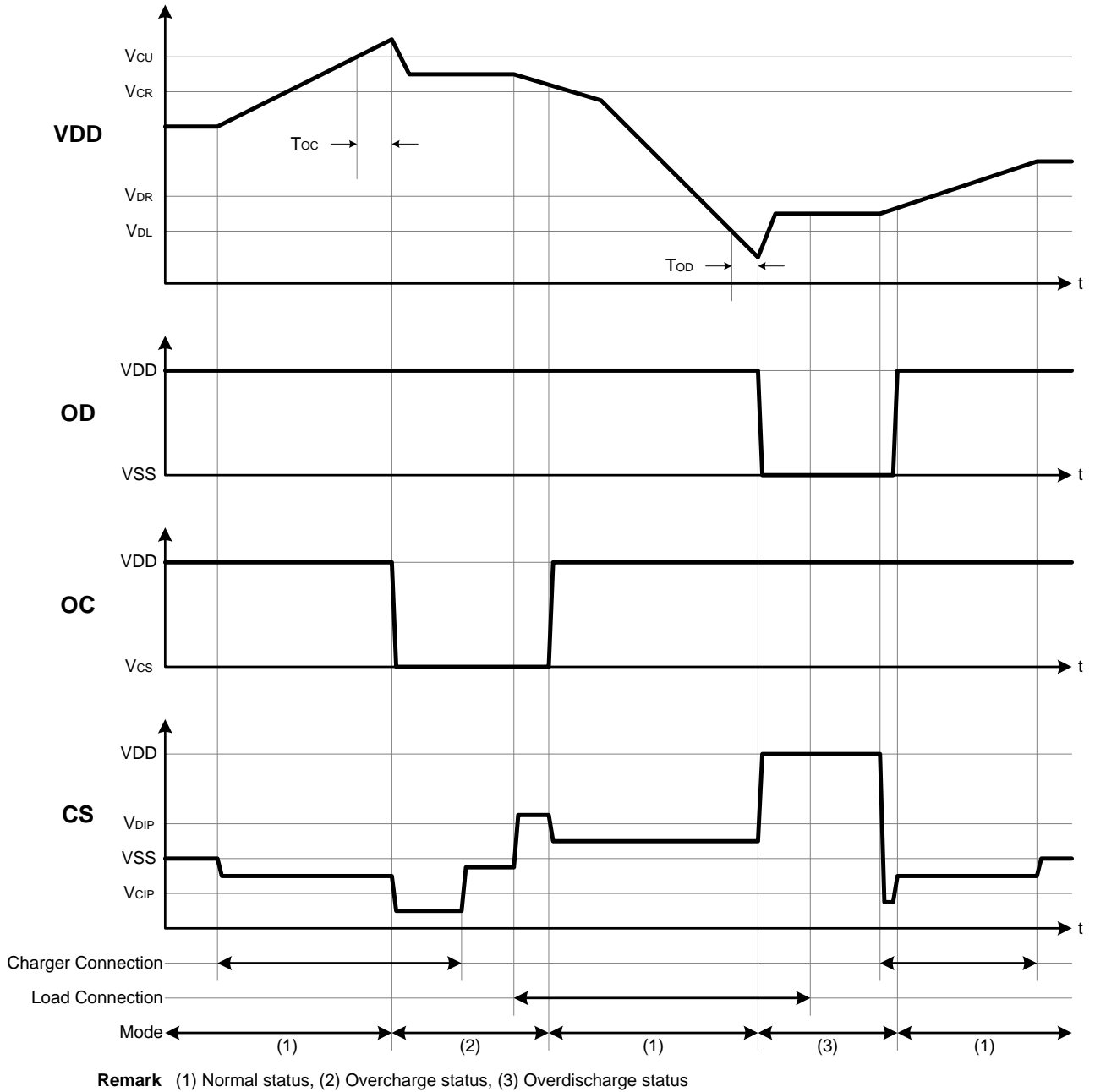

Remark:

- (a) Overcharge release condition: $V_{CS} > V_{DIP}$ & $V_{DD} < V_{CU}$.
- (b) Overdischarge release condition: $V_{CS} < V_{CIP}$ & $V_{DD} > V_{DL}$.

12.2 Overcharge Detection, Overdischarge Detection

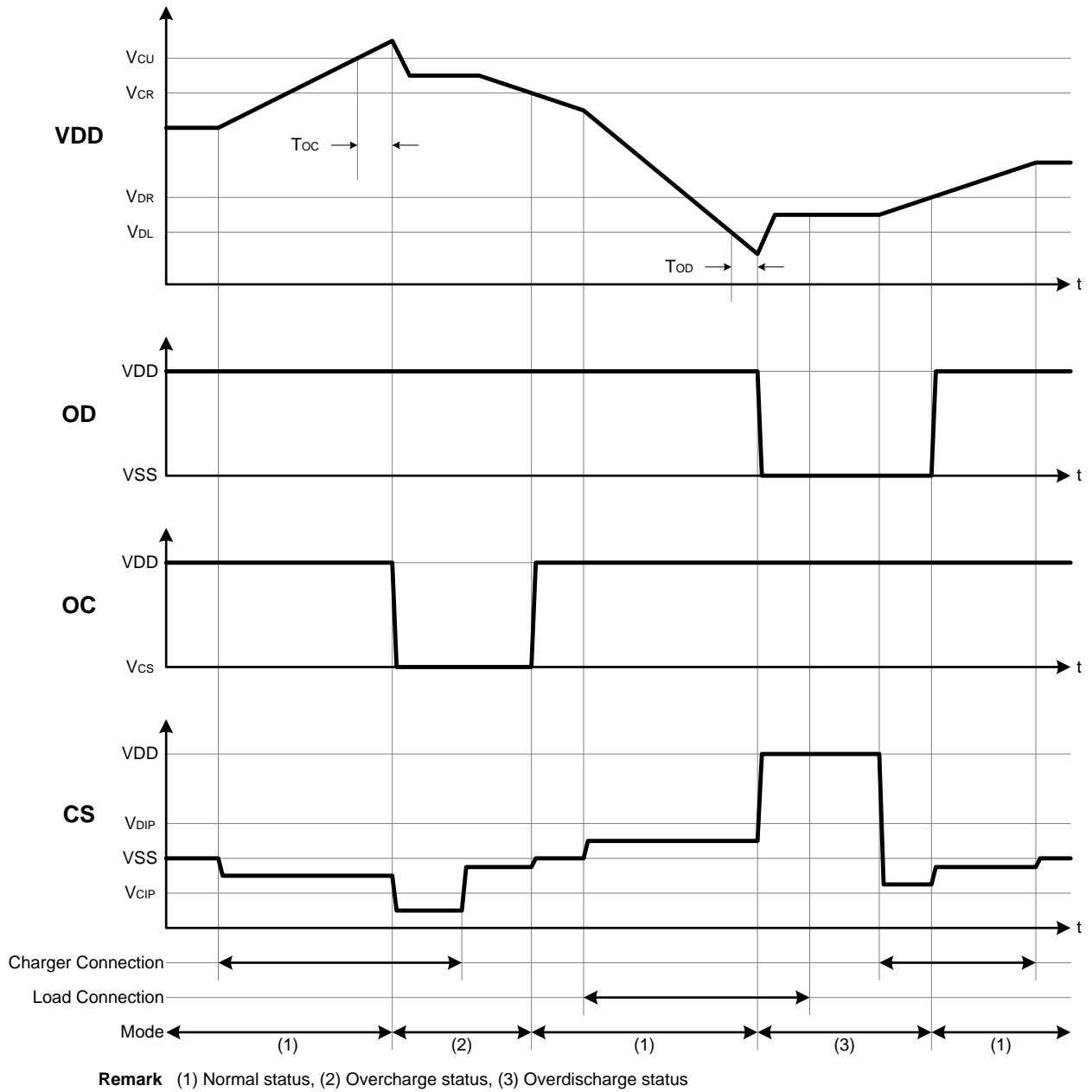

Remark:

- (a) Overcharge release condition: $V_{CIP} < V_{CS} < V_{DIP}$ & $V_{DD} < V_{CR}$.
- (b) Overdischarge release condition: $V_{CS} > V_{CIP}$ & $V_{DD} > V_{DR}$.

12.3 Overcharge Detection, Overdischarge Detection (with auto overdischarge recovery function)

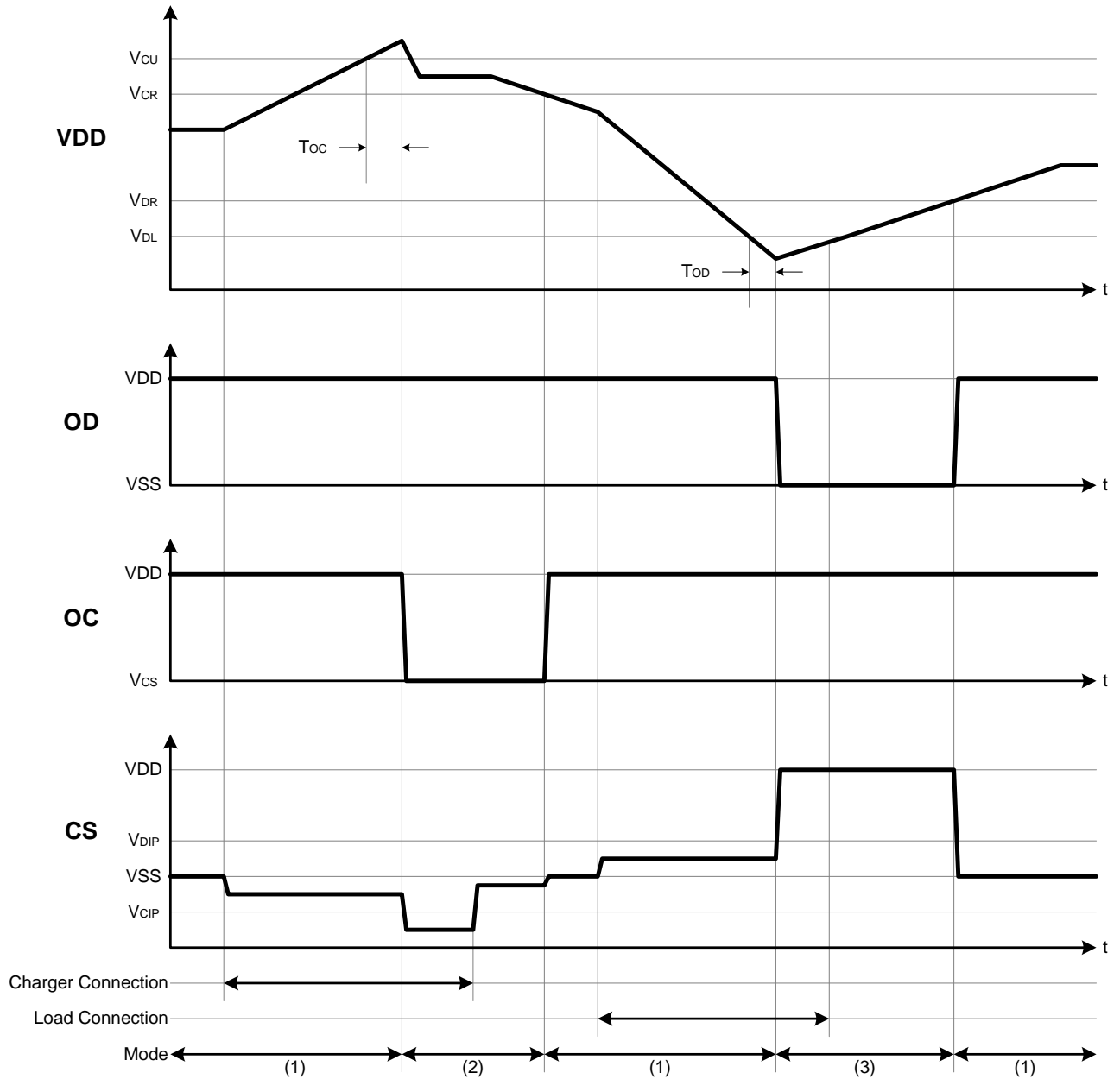

Remark (1) Normal status, (2) Overcharge status, (3) Overdischarge status

Remark:

(a) overcharge release condition: $V_{CIP} < V_{CS} < V_{DIP}$ & $V_{DD} < V_{CR}$.

(b) overdischarge release condition: $V_{DD} > V_{DR}$.

12.4 Discharge overcurrent Detection, Short circuit Detection, Charge Overcurrent Detection

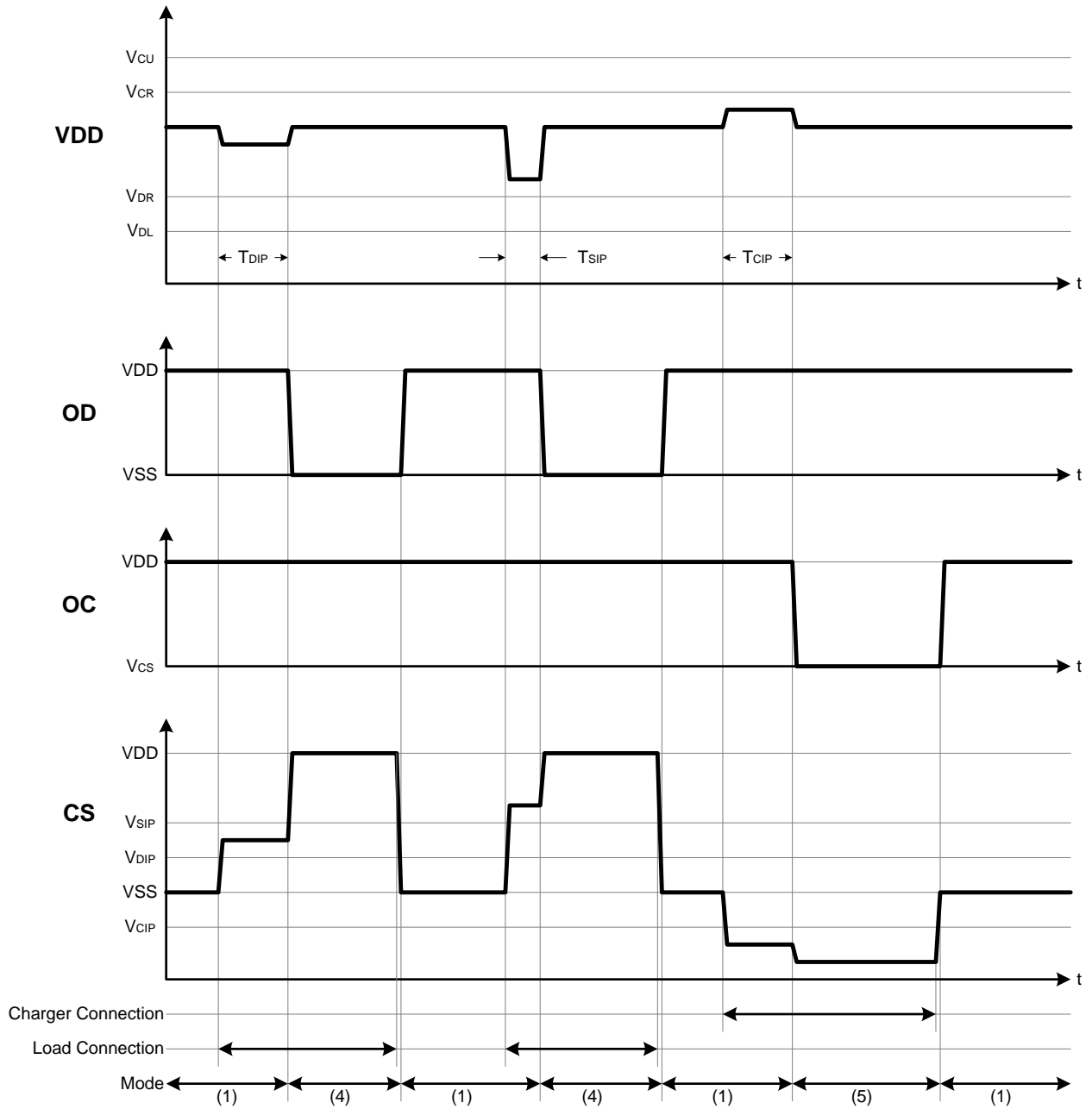

Remark (1) Normal status, (4) Discharge Overcurrent status (Discharge Overcurrent & Short Circuit), (5) Charge Overcurrent status

13. Characteristics (Typical Value)

Overcharge Detection/Release Voltage, Overdischarge Detection/Release Voltage/Discharge Overcurrent Detection Voltage, Short Circuit Detection Voltage, Charge Overcurrent Detection Voltage and Delay Time.

(1) V_{CU} vs. T_a

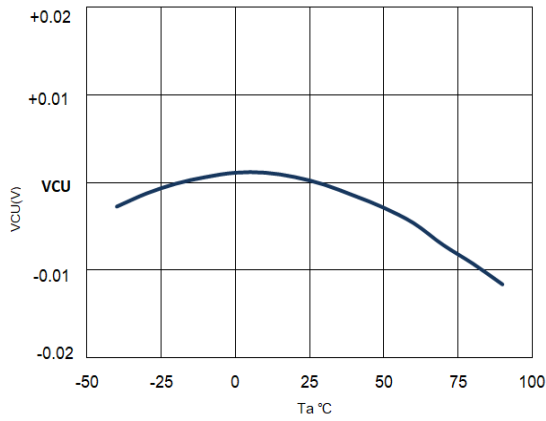

(2) V_{CR} vs. T_a

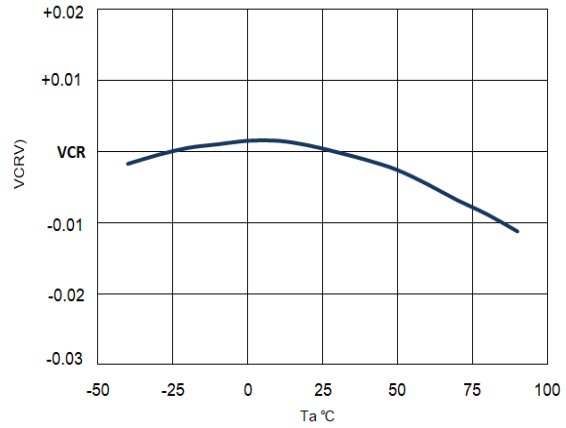

(3) V_{DL} vs. T_a

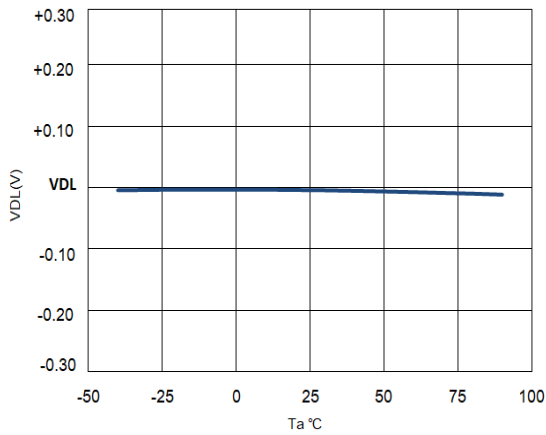

(4) V_{DR} vs. T_a

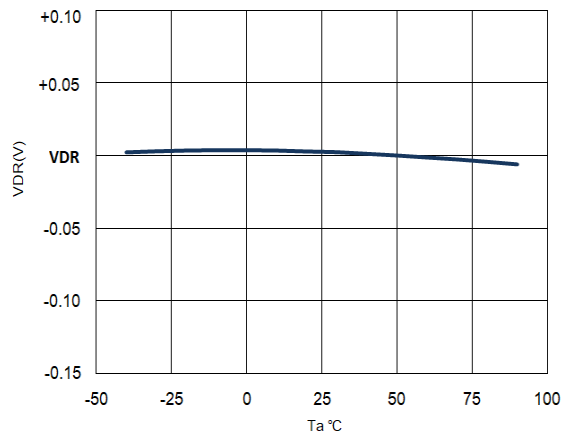

(5) T_{OC} vs. T_a

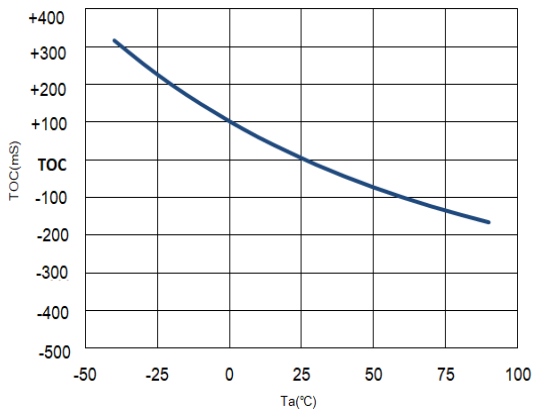

(6) T_{OD} vs. T_a

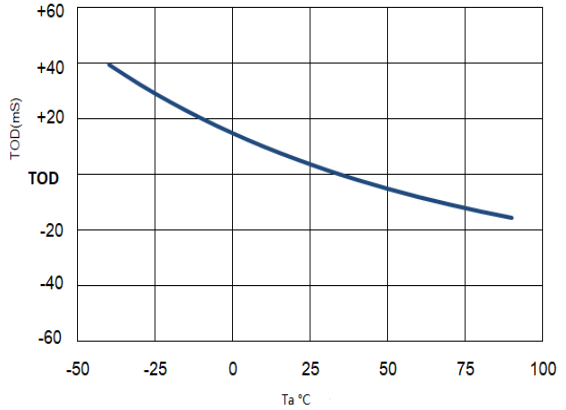

(7) V_{DIP} vs. T_a

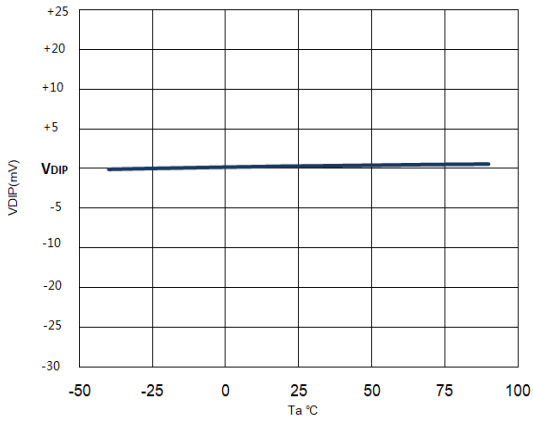

(8) T_{DIP} vs. T_a

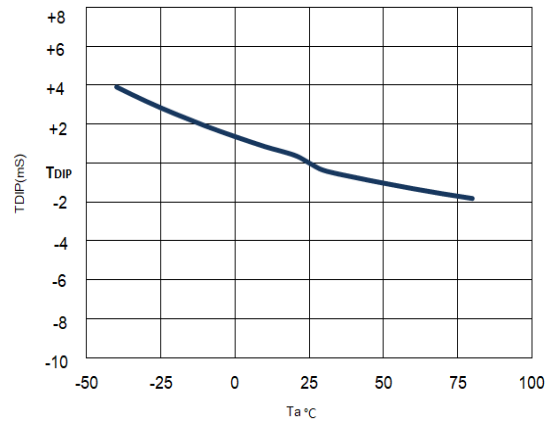

(9) V_{SIP} vs. T_a

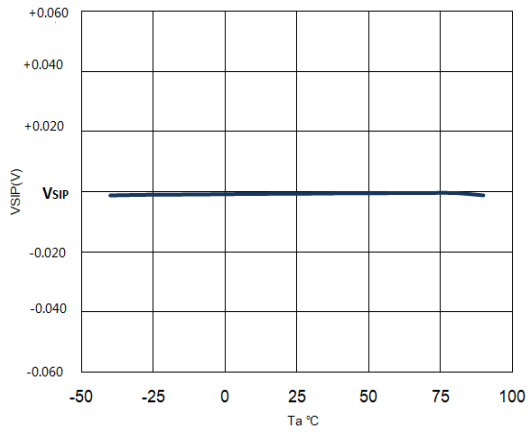

(10) T_{SIP} vs. T_a

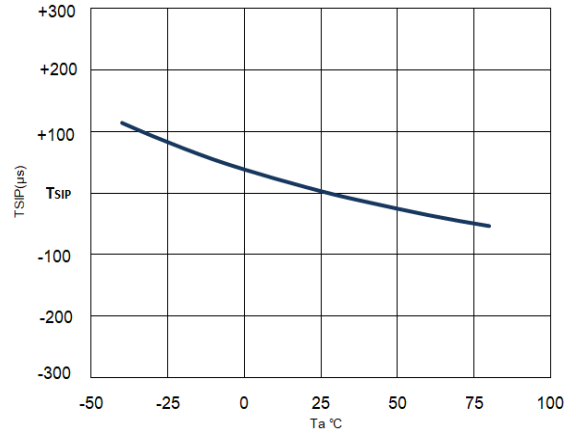

(11) V_{CIP} vs. T_a

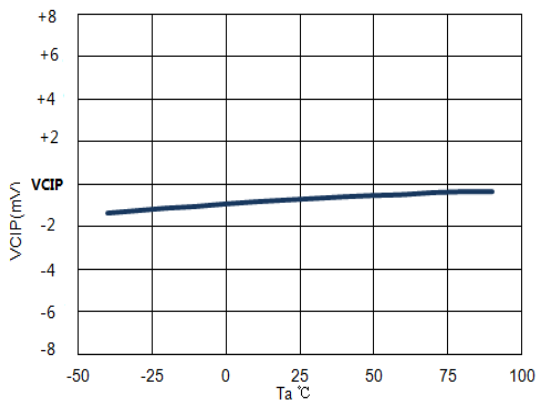

(12) T_{CIP} vs. T_a

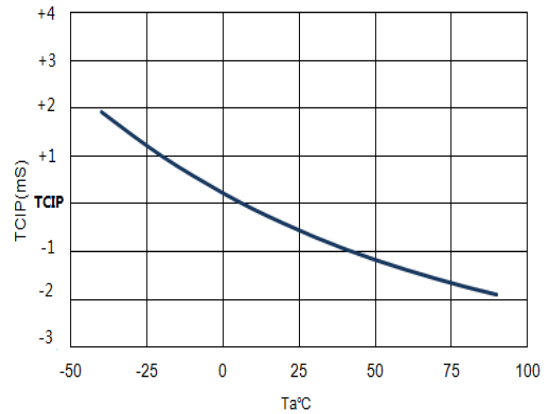

(13) I_{DD} vs. T_a

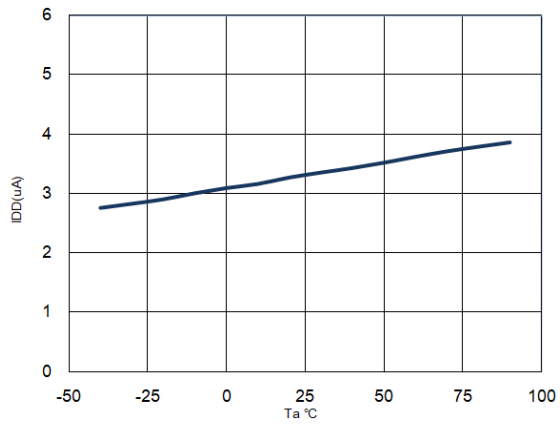

(14) I_{PD} vs. T_a

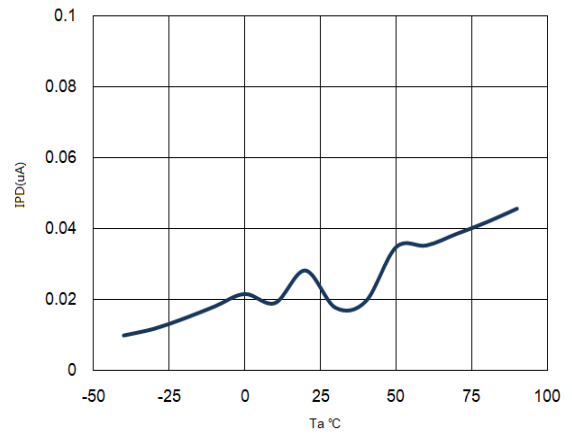

(15) I_{OD} vs. T_a

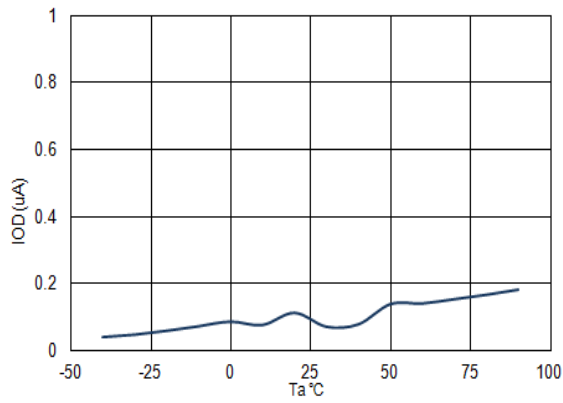

14. Package Information and Land Pattern Design Recommendations

14.1. SON-1.6*1.6-6L Outline

14.1.1. SON-1.6*1.6-6L Outline

Unit: mm.

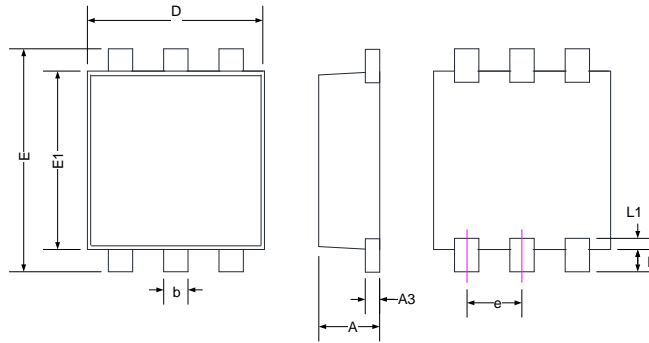

SYMBOLS	MIN	NOM	MAX
A	0.50	0.55	0.60
A3	0.08	0.13	0.18
b	0.17	0.22	0.27
D	1.55	1.60	1.65
E1	1.55	1.60	1.65
E	1.90	2.00	2.10
L	0.10	0.20	0.30
L1	0.10 REF		
e	0.50 BASIC		

Note: Do not include Mold Flash or Protrusions.

14.1.2. Land Pattern Design Recommendations

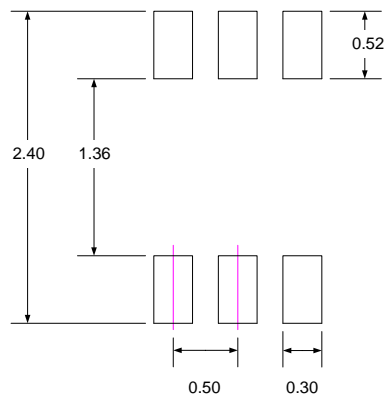

Note:

1. Publication IPC-7351 is recommended for alternate designs.
2. Unit: mm.
3. <http://www.hycontek.com/attachments/MSP/OJTI-HM-2013-002.pdf>.

14.2. SOT-23-6 Outline

Unit : mm

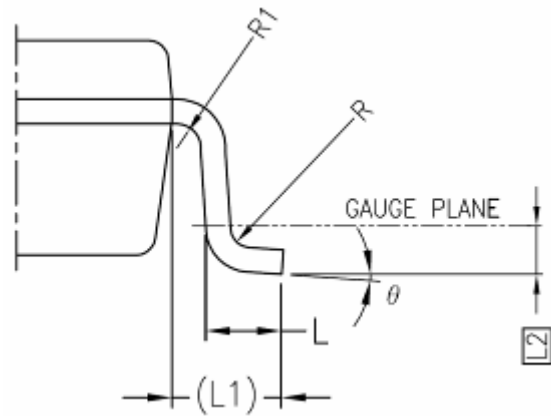
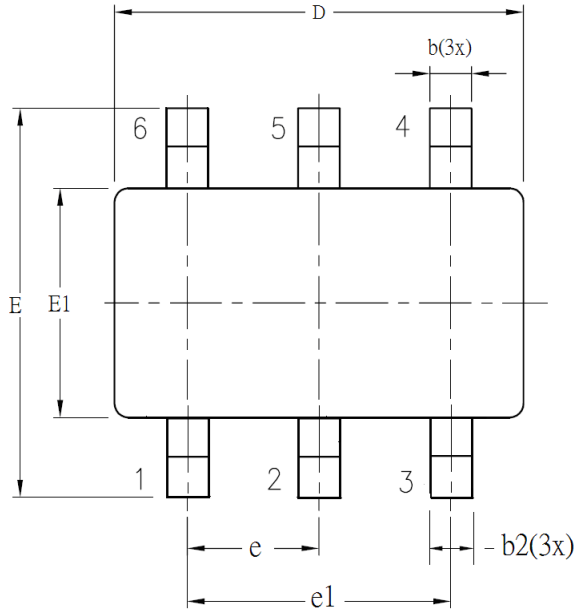

SYM BOL	ALL DIMENSIONS IN MILLIMETERS		
	MINIMUM	NOMINAL	MAXIMUM
A	-	1.30	1.40
A1	0	-	0.15
A2	0.90	1.20	1.30
b	0.30	-	0.50
b1	0.30	0.40	0.45
b2	0.30	0.40	0.50
c	0.08	-	0.22
c1	0.08	0.13	0.20
D	2.90 BSC		
E	2.80 BSC		
E1	1.60 BSC		
e	0.95 BSC		
e1	1.90 BSC		
L	0.30	0.45	0.60
L1	0.60 REF		
L2	0.25 BSC		
R	0.10	-	-
R1	0.10	-	0.25
θ	0°	4°	8°
θ1	5°	-	15°
θ2	5°	-	15°

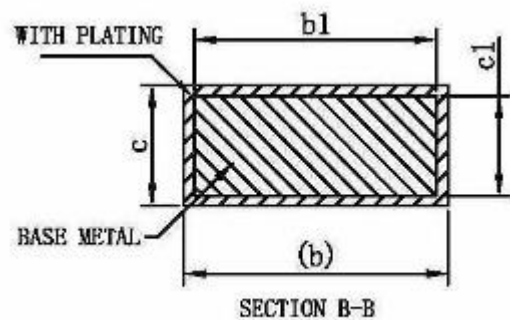
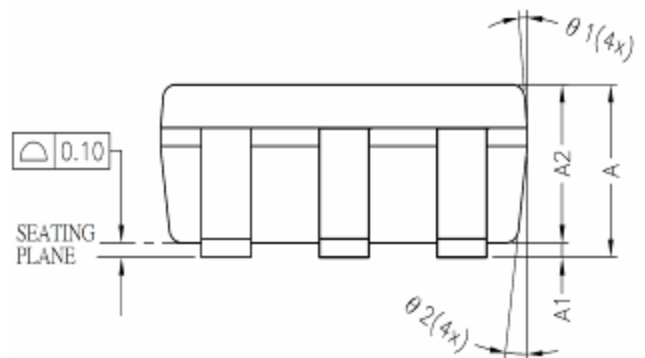

15. Tape & Reel Information

15.1. SON-1.6*1.6-6L

15.1.1. Reel Dimensions

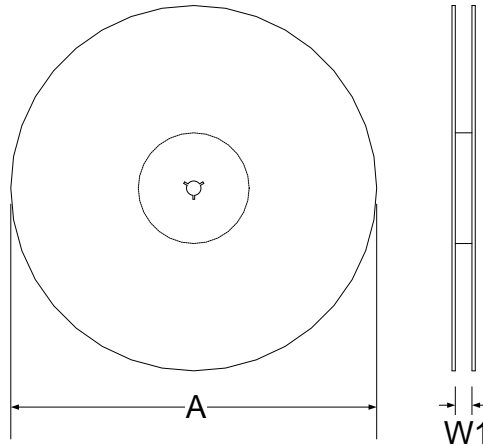

15.1.2. Carrier Tape Dimensions

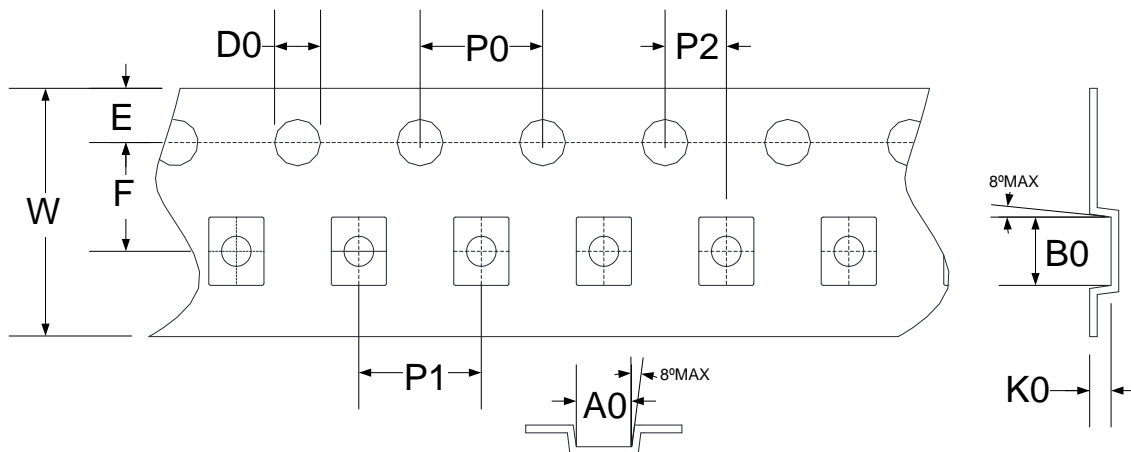

SYMBOLS	Reel Dimensions		Carrier Tape Dimensions									
	A	W1	A0	B0	K0	P0	P1	P2	E	F	D0	W
Spec.	178	9.4	1.80	2.20	0.70	4.00	4.00	2.00	1.75	3.50	1.50	8.00
Tolerance	± 2.00	± 1.50	± 0.05	± 0.05	± 0.10	± 0.10	± 0.10	± 0.05	± 0.10	± 0.05	± 0.10	± 0.20

Note: 10 Sprocket hole pitch cumulative tolerance is $\pm 0.20\text{mm}$.

15.1.3. PIN1 direction

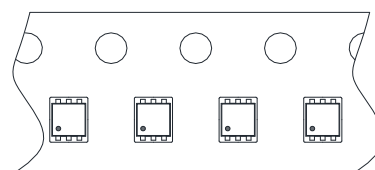

15.2. Tape & Reel Information---SOT-23-6 (Type 1)

Unit: mm.

15.2.1. Reel Dimensions

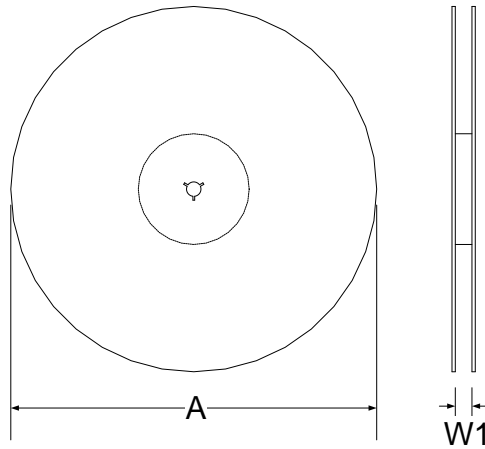

15.2.2. Carrier Tape Dimensions

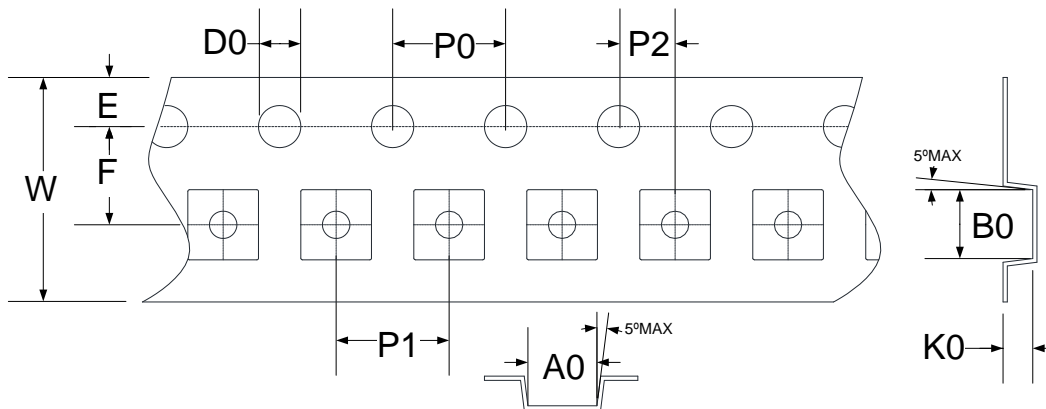

SYMBOLS	Reel Dimensions		Carrier Tape Dimensions									
	A	W1	A0	B0	K0	P0	P1	P2	E	F	D0	W
Spec.	178	9.0	3.30	3.20	1.50	4.00	4.00	2.00	1.75	3.50	1.50	8.00
Tolerance	±0.50	+1.50/-0	±0.10	±0.10	±0.10	±0.10	±0.10	±0.10	±0.05	±0.10	±0.05	+0.1/-0 ±0.20

Note: 10 Sprocket hole pitch cumulative tolerance is ±0.20mm.

15.2.3. Pin1 direction

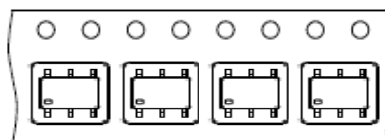

15.3. Tape & Reel Information---SOT-23-6 (Type 2)

Unit: mm.

15.3.1. Reel Dimensions

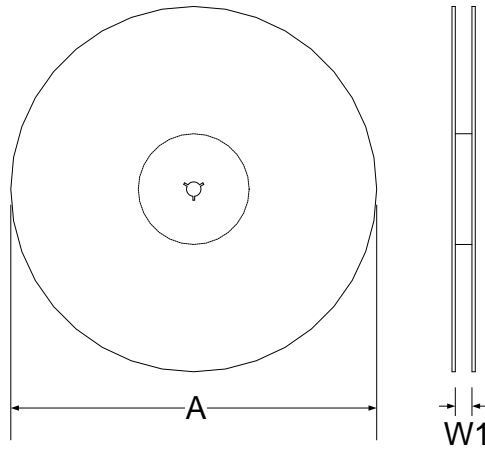

15.3.2. Carrier Tape Dimensions

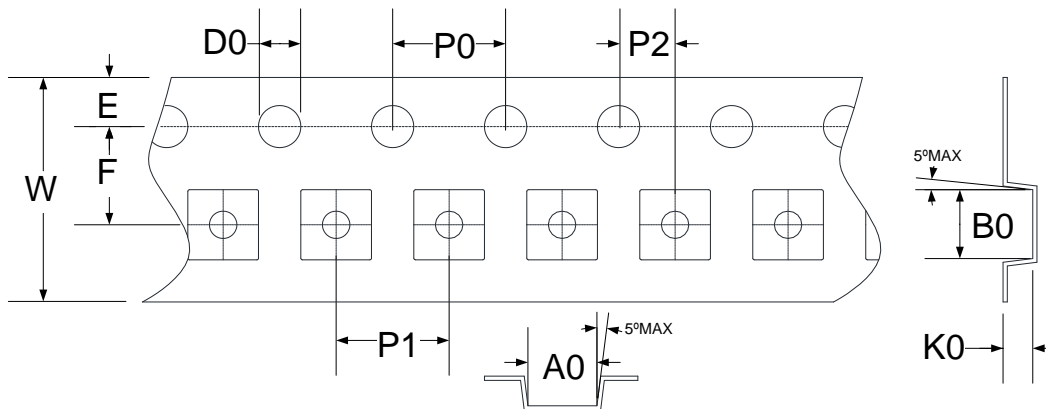

SYMBOLS	Reel Dimensions		Carrier Tape Dimensions										
	A	W1	A0	B0	K0	P0	P1	P2	E	F	D0	W	
Spec.	178	9.4	3.17	3.23	1.37	4.00	4.00	2.00	1.75	3.50	1.55	8.00	
Tolerance	±2.00	±1.50	±0.10	±0.10	±0.10	±0.10	±0.10	±0.10	±0.05	±0.10	±0.05	±0.05	+0.30/-0.10

Note: 10 Sprocket hole pitch cumulative tolerance is ±0.20mm.

15.3.3. Pin1 direction

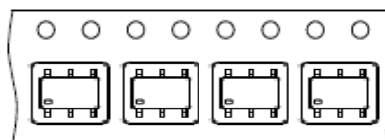

16. Revision Record

Major differences are stated thereafter:

Version	Page	Revision Summary
V01	-	First Edition.
V02	-	Renew the spec.